

Puraflo[®]

Peat Fiber Biofilter

Reference Manual

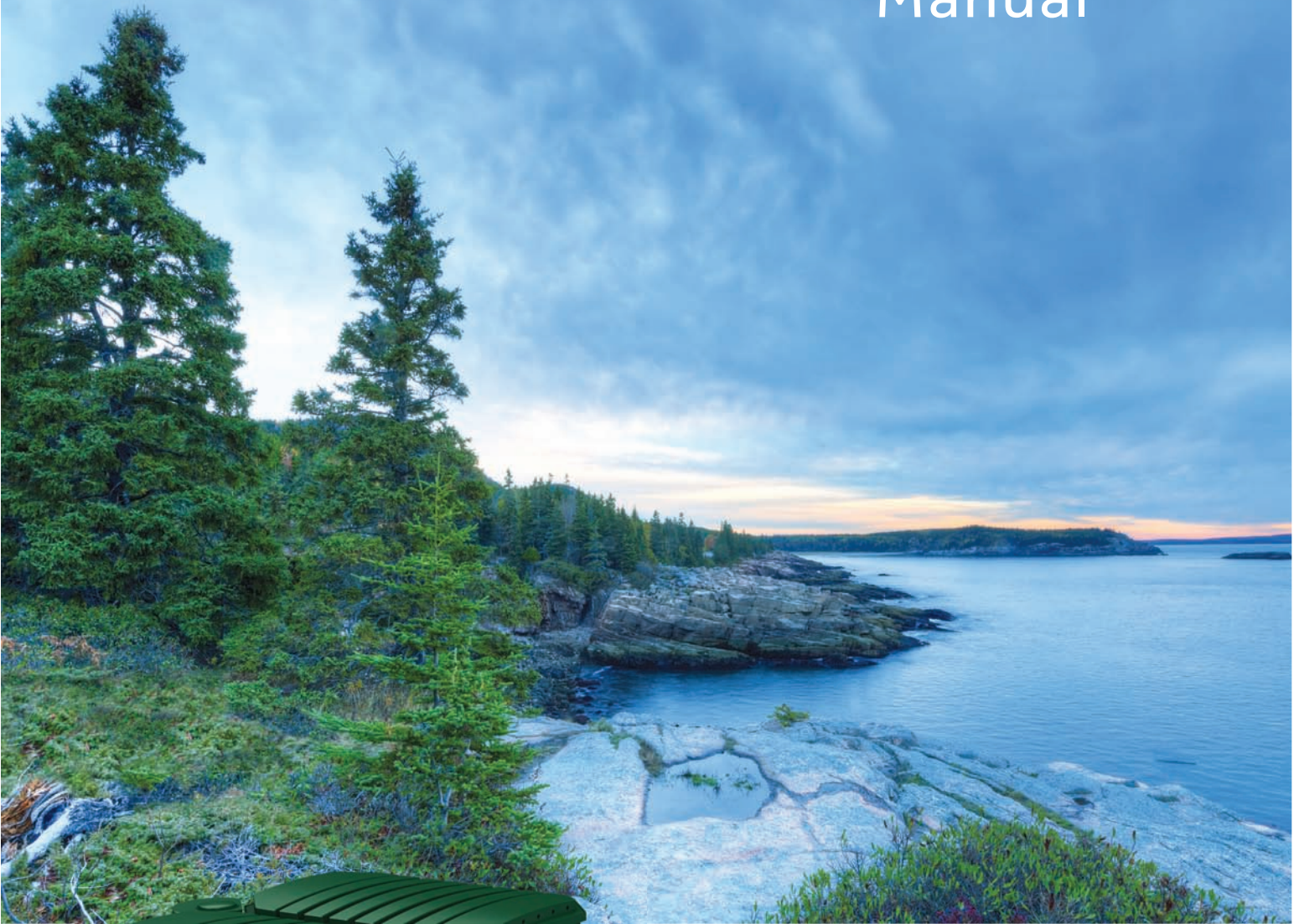

Only modules bearing the NSF[®] logo and designated P150N*XX are certified to NSF/ANSI Standard 40



©2018 Anua 2-2018

336.547.9338 ■ anuainternational.com

Table of Contents

1.0	General Description of System	1
2.0	Process Fundamentals	2
2.1	Treatment Mechanisms	2
2.2	Microbiology of the System	3
2.3	Treated Effluent Quality	4
3.0	Media Filters	4
3.1	System Features	4
3.2	Comparison of Puraflo and Single Pass Sand Filter Treatment	5
4.0	Summary	7
5.0	System Design and Specification	7
5.1	System Configuration	7
5.2	Design Flow and Number of Modules	7
5.3	Septic Tank	7
5.4	Timed Dose Pump Tank	7
5.5	Biofilter Modules	8
5.6	Cold Weather Conditions	11
5.7	Life of the Peat Fiber Media	11
5.8	The final disposal system	11
6.0	System Layout and Components	12
6.1	Schematic of Puraflo System Components	12
6.2	Specification of Puraflo Module	12
7.0	Installation Requirements	13
8.0	Electrical Requirements	13
9.0	Sequential Installation Procedure	14
9.1	Site Clearance	14
9.2	Septic Tank	14
9.3	Pump Tank Installation	14
9.4	Pump Fittings and Pipework	14
9.5	Puraflo installation	15
9.6	Electrical Connections	16
9.7	Spare Parts	17
9.8	Site Restoration	17
Appendix 1	Typical Septic Tank and Pump Tank Detail	18
Appendix 2	Type A and B Installation	19
Appendix 3	Assembled Module Detail	20
Appendix 4	Module Grid Detail	21
Appendix 5	Sample Chamber Detail	22
Appendix 6	Module Pictures	23
Appendix 7	Information Needed for the Drawdown Test	24
Appendix 8	Criteria for Dn (recirculation) Model for Denitrification	26
Appendix 9	Additional Effluent Dispersal Criteria	28
	References	39
	Additional References	40

1.0 General Description of System

The Puraflo peat fiber biofilter is an advanced secondary treatment system that purifies septic tank effluent to an extremely high degree before final dispersal.

A typical Puraflo peat fiber biofilter system consists of:

- Septic tank with a commercially-rated effluent filter, with 1/32" filtration, connected to the tank outlet pipe
- Dosing tank and effluent pump, or siphon, to accommodate dosing of the septic tank effluent onto the peat fiber media
- Biofilter modules where advanced treatment occurs due to the physical, chemical and biological processes that are optimized in the peat fiber media.
- Site specific, final effluent dispersal system

The filtered septic tank effluent is collected under gravity in the pump tank. A timed dosing system is activated by a programmable timer or a siphon-dose system triggers, which

pumps the effluent through a flow splitting inlet manifold located at the base of the treatment modules. An orifice plate is located inside the top of each inlet manifold which allows the flows to be split equally and fed simultaneously to each biofilter module. The inlet manifold is connected to the base of the biofilter module and is fed upwards to a rectangular distribution grid located 6 inches below the top of lid. The effluent percolates laterally and vertically through the depth of the peat fiber treatment media and emerges as a clear, innocuous liquid from the base of the system. The treated effluent is then collected and dispersed.

The Puraflo peat fiber biofilter system has been rigorously tested over the past three decades, in both a certification setting and a field setting. Puraflo has been tested as part of USEPA National Onsite Demonstration Projects, State Onsite Demonstration Projects, and per state/local regulatory requirements. Testing has demonstrated Puraflo's ability to provide high level treatment for biological, chemical, and physical constituents. Puraflo is a modular system with each module rated according to application.

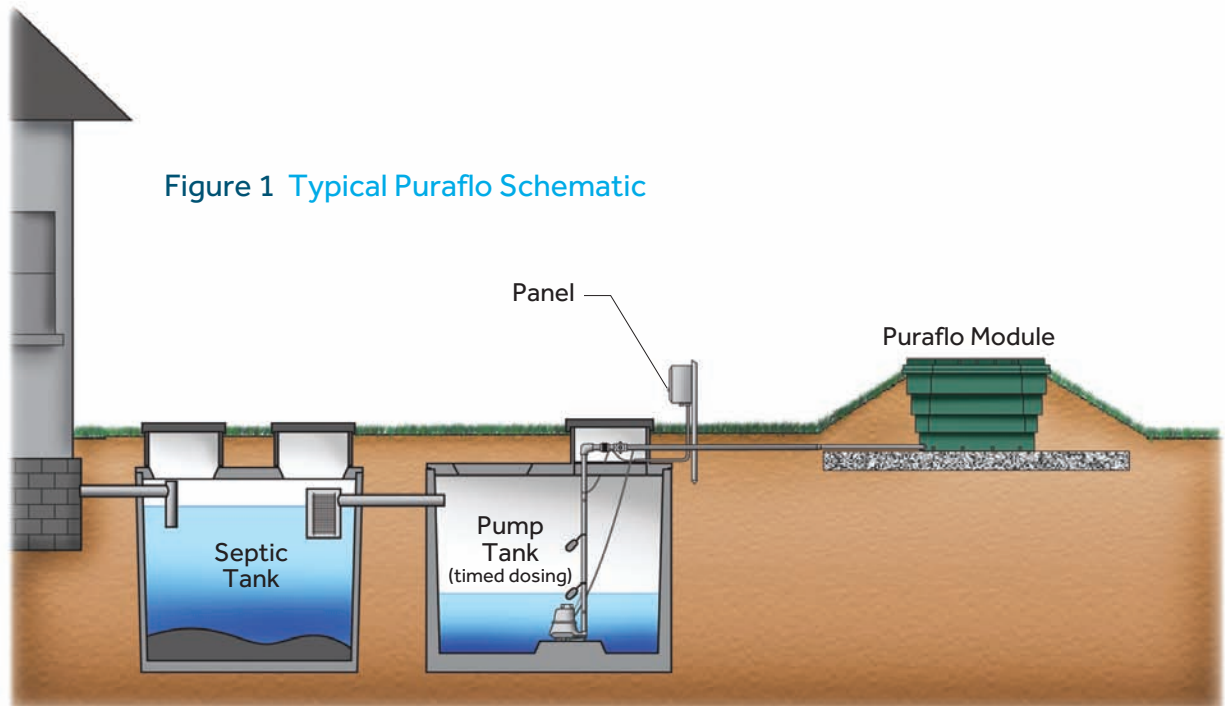

Figure 1 Typical Puraflo Schematic

2.0 Process Fundamentals

2.1 Treatment Mechanisms

The Puraflo peat fiber biofilter treatment technology is based on simple, passive biofiltration principles. The treatment of the effluent within the system is achieved by a combination of unique physical, chemical, and biological interactions between the effluent and the fibrous peat media. The residence period or contact time in the media at the design loading rate has been calculated and demonstrated to be somewhere between 36 and 48 hours by using tracer organisms.

Extensive scientific examination of the peat fiber media has revealed a complex structure which permits a number of separate treatment and attenuation processes to occur simultaneously. The treatment mechanisms within the fixed film media are summarized in the table below.

Table 1 Treatment Mechanisms

Treatment	Characteristics	Significance
Physical	Surface Area	Greater the surface area, greater the contact between effluent, air and media
	Void Space	Open fibrous structure and large pore volume results in efficient transfer of air and effluent throughout the biofilter
	Bulk Density	Low bulk density media – light open material resulting in large surface area and void spaces, characteristics attractive in respect to treatment.
Chemical	pH	Pathogenic bacteria undergo significant die-off in peat due to the acidic conditions prevailing and the predation/competition from naturally occurring pH tolerant microfauna.
	Cation Exchange Capacity (CEC)	Peat particles tend to be negatively charged. This gives peat a great ability to absorb positively charged molecules. A high CEC means the peat can effectively hold positively charged molecules including ammonium, metals, pesticides, some organic molecules and possibly viruses.
	High Adsorptive Surface Area	The larger the surface area the greater the number of adsorption reactions taking place
Biological	Buffering Capacity	The ability of the system to withstand shock loadings
	Resistance to Degradation	Due to a high lignin content, peat fiber is resistant to breakdown or decay thus prolonging the life span of the media
	Beneficial organism growth	Biological treatment achieved by complex and diverse microflora which adhere to peat fiber media. Microflora largely composed of aerobic and facultative aerobic heterotrophic bacteria from different genera. Supports higher life forms : protozoans, rotifers, algae, insects, nematode and annelid worms.

2.2 Microbiology of the System

In a mature peat fiber unit the biological processes are known to be crucial in maintaining the treatment efficiency observed. The bulk of the treatment and assimilation processes are achieved by diverse microflora which adhere to the surface of the peat media. This microflora is largely composed of aerobic and facultative aerobic heterotrophic bacteria from a large number of genera. The most important bacteria genera represented include:

- Pseudomonas
- Aeromonas
- Bacillus
- Micrococcus
- Flavobacteria
- Alcaligenes
- Streptococcus

The total bacterial population recorded per gram of peat

has been measured at 1×10^9 cfu. Similarly, high numbers (up to 1×10^7 cfu/g) of fungal organisms have been isolated from the Puraflo units. A wide variety of "higher life" forms have also been recorded within the media matrix (ranging from protozoans, rotifers, and algae to nematode and annelid worms, insects and their larvae). These organisms play an important role in keeping the bacterial population "in check" thereby maintaining balanced microflora and ultimately a stable ecosystem.

The larger numbers of heterotrophic bacteria are found in the upper portions of the filter media with nitrifiers becoming more prevalent at depths of 12" or greater. Therefore, the degradation and assimilation of the carbonaceous elements of the waste is affected within the upper portions of the filter bed with nitrification occurring at greater depths.

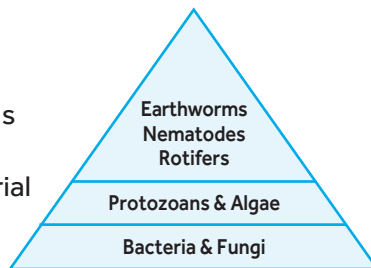

The peat fiber system is also very effective at eliminating enteric bacteria contained in the waste. The antimicrobial properties of the system can be classified under two broad headings:

Aggressive nature of the peaty media

The anti-microbial properties of the acidic peaty soils are developed through the low pH which directly affects the cell walls of the organisms in addition to limiting the amounts of nutrients available for uptake. Also, the trace amounts of phenols, bitumes and other complex hydrocarbons which are associated with peaty materials are directly toxic to certain bacteria, in particular enteric organisms which find themselves in a hostile environment (low temperature, high competition, etc.) and are already in a stressed condition. Finally, certain peaty soils have been demonstrated to contain a significant fungal species population (in addition to certain actinomycetes) which produce antibiotics and thus can adversely affect bacterial species in the zone of influence. It is important to note that the natural anti-microbial properties of the peat fiber media are only effective on the "stressed" enteric organisms. The indigenous microflora associated with the treatment media are largely unaffected by the properties described.

Microbial antagonism

The second means by which the enteric organisms are extinguished in the Puraflo system is by microbial antagonism. This simply means that the stressed micro-organisms are out competed by the indigenous microflora. The low temperature, low pH and production of certain microbial toxins within the peat fiber media adversely affects the "foreign" organisms. As such, they are largely ineffective in assimilating nutrients and other constituents, which are necessary for their survival. The large retention time in the peat fiber media ensures maximum lethality.

2.3 Treated Effluent Quality

When treating domestic strength sewage (300 mg/l BOD₅ or less) up to the design flows and loads, a properly maintained Puraflo peat fiber biofilter system will typically perform better than the 30-day average requirements of NSF Standard 40 Class 1 (25 mg/l CBOD₅ and 30 mg/l TSS).

Reductions in the CBOD₅ and suspended solids (TSS) influent concentrations will be attained within a few weeks of commissioning and should be consistently achieved over the lifetime of the peat fiber media.

CBOD₅ and suspended solids (TSS) treatment performance in the peat fiber media is not subject to significant variation with ambient air temperature fluctuations.

Table 2 Treatment Performance

Parameter	NSF Std 40 Avg, 30-day	Puraflo Effluent NSF Std 40 Avg	Puraflo Effluent NSF Std 40 Max Result
CBOD ₅ (mg/l)	25	2	9
TSS (mg/l)	30	2	6
pH	6 - 9	6.4 - 7.4	7.4

Note:

All modules use identical components except those with limestone in underdrain (e.g. NSF 40 model) have 1 ft³ of limestone substituted for 1 ft³ of granite. Total underdrain stone = ~4.5 ft³ per module

3.0 Media Filters

3.1 System Features

The Puraflo peat fiber biofilter system has been part of numerous field studies and observations. Keys aspects of single pass media filters are:

- Primary treatment (septic tank)
- Septic tank effluent screening (effluent filter or screened pump vault)
- Timed dosing in small, even increments
- Hydraulic loading
- Organic loading
- Air ventilation
- Media properties
- Media depth
- Media replacement or adjustment

Using the criteria listed above, Table 3 provides a technology summary per module.

Table 3 Technology Summary

Parameter	Puraflo
Primary treatment (septic tank)	Yes
Effluent screening	Effluent filter 1/32" filtration
Timed dosing	Yes
Air ventilation	Surface access (holes in side of module lid)
Area	26.93 ft ²
Hydraulic loading	5.57–11.14 gpd/ft ²
Organic loading	0.0029–0.0140 lbs BOD ₅ /ft ² /d
Media depth	24"
Media void space	90 - 95%
Water holding capacity, % volume	50 - 55%
Media size	1 - 10mm
Media surface area	52,000 ft ² /ft ³
Media replacement	~15 years (single pass mode) (non-polishing filter mode)
Effluent BOD ₅ , typical	<10 mg/l
Effluent TSS, typical	<10 mg/l
Effluent fecal coliform range, geo mean	<1,000 - <10,000 per 100 ml

Some Table 3 values derived from:

Loudon, T.L., T.R. Bounds, J.R. Buchanan and J. C. Converse. "Media Filters Text." in (M.A. Gross and N.E. Deal, eds.) University Curriculum Development for Decentralized Wastewater Management. National Decentralized Water Resources Capacity Development Project. University of Arkansas, Fayetteville, AR. 2005.

3.2 Comparison of Puraflo & Single Pass Sand Filter Treatment

To review, the Puraflo Peat Fiber Biofilter and the Single Pass Sand Filter, employ three main treatment mechanisms:

- Biological
- Chemical
- Physical

The media properties dictate the level of treatment expected under each mechanism. Within a mature media filter (all types), biological treatment predominates, confirmed by the following statements:

- The effluent from this sand filter during the experiments was purer than many drinking-water supplies, and the last published analysis, after the tank has been in operation 14 years, indicate that the sewage that was applied to it in 1901 was freed from 89 per cent. of its organic impurities. At first thought, this purification might be attributed to the fact that the sewage is strained through the sand. Such is not the case, however. Most of the organic impurities have been absolutely destroyed or transformed into other and inoffensive combinations, mainly through the action of bacteria (International Library of Technology 440, 1926).

- Treatment filters using sand or peat as media make effective attached growth systems. They can be designed as either single-pass or recirculating filters, meaning that the wastewater is run across the media more than one time. Regardless of the media, the process is generally the same—wastewater from the septic tank is allowed to run through a bed of media and collected from underneath. Treatment occurs as the bacteria grows on the media (NESC, 2004).

- As the wastewater passes through the sand filter, treatment is accomplished through physical and chemical means, but mainly by microorganisms attached to the filter media (NFSC, 1998).

- A biologically active film of organisms forms on the surface of the media. Microorganisms play an essential role in treating the wastewater as it flows over media surfaces. Certain bacteria known as primary colonizers attach (via adsorption) to the surfaces and differentiate to form a complex, multi-cellular structure known as a biofilm (Loudon, Bounds, Buchanan and Converse, 2005).

- The bulk of the treatment and assimilation processes are achieved by a diverse microflora which adhere to the surface of the peat media (Walsh and Henry, 1998).

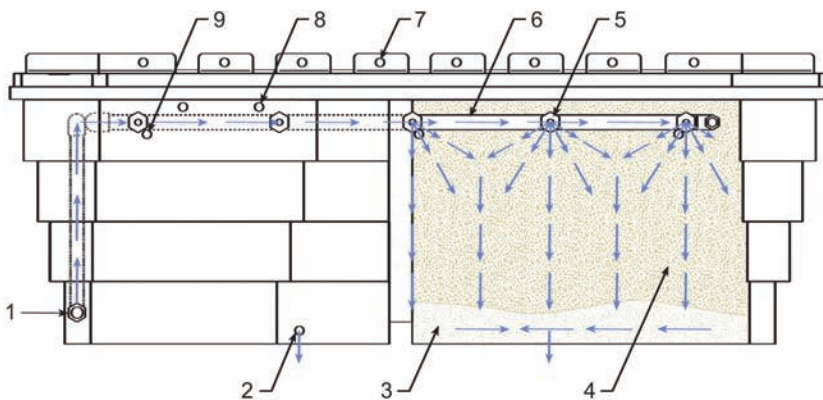

Item	Description
1	Inlet
2	Outlet Port
3	#5 Stone
4	Peat Fiber Media
5	Distribution Orifice
6	Distribution Grid
7	Vent Holes
8	Rope Handle Holes
9	Stabilizer Bars

As shown on page 5, the Puraflo Peat Fiber Biofilter and the Single Pass Sand Filter have similar performance characteristics. The media employed within the Puraflo Peat Fiber Biofilter has some unique properties that enhance treatment and that are worth noting:

- Surface area: 52,000 ft²/ft³
- Void space: 90-95%
- Water holding capacity: 50-55%
- Retention time: 36-48 hours
- Cation Exchange Capacity (CEC): 125 mg/g

Patterson (2004) outlines the roles identified above in the treatment process:

- **Physical properties - filtration:** the small particulate matter (usually high in BOD₅) that passes through the septic tank treatment is captured within the interstices of the peat fiber, and does not percolate through the peat with the drainage water. Thus, the loading of BOD₅ and TSS at the top of the peat can be significantly higher than the quality from average septic tanks.
- **Biological properties – microbial decomposition:** the peat fibers support a significant population of microbes which consume organic matter in the incoming primary treated effluent in much the same way as the zoogeal film in a trickling filter consume the organic loading in a conventional sewage treatment works. In the peat system, the actual surface area of the peat fibres is many thousand times that of the trickling filter. This fact is borne out by the very high CEC of the peat that is a direct relationship with surface area. The 99.2% removal of fecal coliform without any external disinfecting agent indicates the efficacy of the peat as a disinfecting medium. The naturally high acidic properties of the peat also play a role in the disinfection process.
- **Biological properties – aerobic environment:** similar to an aerated wastewater treatment system, a highly developed population of aerobic bacteria is maintained within this environment. Laboratory results show that the peat can hold up to 300% of its own weight in water and maintain an air-filled capacity of more than 30% (about that of a soil at field capacity). This high aeration is confirmed by the ability of the peat to oxidize up to 96% of the ammonia-N in the STE.
- **Chemical properties:** the high CEC of the peat and its mineral content resulted in the changes to the cation ratios from the start of the trial to the end, reflected in the reduction in sodium adsorption ratio of the effluent in its transit through the peat. The loss of 74.6% of TP by adsorption is a highly significant reduction without further chemical additions. The reduction in salinity by 38% and the loss of 81.5% of alkalinity are further chemical changes induced by the peat environment. These losses are statistically significant.

Headley (2006) describes some aspects of chemical and physical treatment:

- Peat can be described as partially fossilized plant matter which accumulates in wet areas (wetlands) where there is a lack of oxygen and the accumulation of the plant material is more rapid than its decomposition (Couillard, 1994; Viraraghaven, 1993). Peat is a porous, complex material containing lignin and cellulose as major constituents. These constituents contain polar functional groups, such as alcohols, aldehydes, ketones, acids, phenolic hydroxides, and ethers than can be involved in chemical bonding (Viraraghaven, 1993). This polar nature gives peat a high specific adsorption capacity for suspended and dissolved solids, such as transition metals and polar organic molecules. The particulate and highly porous nature of peat also makes it an effective physical filter (Perez et al. 2005). Studies have shown that partially decomposed peat has a relatively high porosity of approximately 95% and a specific surface area of 200 m² per gram.

Kennedy and Van Geel (2000) make the following observation:

- Peat is an alternative filter medium for the treatment of various waste streams including septic tank effluent. The water holding capacity and adsorption capacity of peat make it a favorable filter medium over sand or gravel which are commonly used as the filter medium for the drainage field of septic systems.

4.0 Summary

From the long history and wealth of studies done on peat biofilters it can be concluded that the treatment capability and performance is equivalent, or better, to a single pass sand filter.

Headley (2006) offered the following comments and comparisons:

- Peat filters offer significant potential as a relatively passive, low-maintenance and robust secondary treatment device for on-site systems in the Gisborne region. Experience with peat filters internationally indicates that they are highly effective at removing TSS and BOD, and are more effective at removing pathogen indicators than similar fixed-bed filters using other media, such as sand or gravel. Peat filters have also been shown to be highly effective at nitrifying domestic wastewater, and in many cases are capable of removing 30-50% of the total nitrogen load.
- Field evaluations of peat filters used in on-site systems indicate that they are relatively robust under the typically variable loadings experienced in domestic situations (Patterson. 1999). They also represent a relatively low maintenance and passive treatment system, especially compared to package aerated wastewater treatment systems which generally require at least quarterly servicing by a trained technician. For example, Patterson (1999) reported that a domestic peat filter required only two hours of active maintenance in over 13 years of successful operation (1986-1999).

5.0 System Design & Specification

The Puraflo Peat Fiber Biofilter is a pre-engineered treatment system contained in factory pre-assembled molded polyethylene modules. It is a highly efficient system designed to minimize site construction. Domestic quality primary effluent is evenly distributed over the specialized fibrous peat fiber media.

5.1 System Configuration

The designer of a Puraflo system will be responsible for proper configuration and sizing of the components of the system, pump and other peripheral component specifications, timer settings, and construction details.

5.2 Design Flow & Number of Modules

Applicable regulations usually define the daily flow based on the number of bedrooms or the number of occupants with a defined flow per person per day. One module (7.1' L x 4.5' W x 2.5' H) is designed for one bedroom, two people, or a design flow of up to 150 gallons per day of primary effluent. Guideline hydraulic and organic loading rates per module are as follows:

- Maximum organic loading per module
0.3755 lbs/d
- Maximum hydraulic loading per module
150 gpd (residential);
120 gpd (commercial);
240-300 gpd (polishing or recirculation)

5.3 System Configuration

The size and configuration of the septic tank shall be in accordance with the NSF listing (as applicable) or State or Local requirements. The septic tank shall have a usable volumetric capacity of at least 24 hours retention. The septic tank, risers and lids must be watertight.

A commercial effluent filter with 1/32 inch filtration must be specified. Acceptable commercial effluent filters are the Bear

Onsite ML3-932, Zabel A300, BEST GF10-32, Lifetime Filter LT9-1/32, and Polylok PL-625 (alternatively, the Sim/Tech Pressure Filter STF-100 may be used). The effluent filter is installed on the septic tank outlet pipe to prevent grease and solids carryover into the pump tank.

5.4 Timed Dose Pump Tank

Dosing is typically regulated by a control panel with programmable timer, low water cut-off float and high water alarm float. The low water cut-off should ensure that the pump remains covered at all times. Storage capacity above the high water alarm float equal to or greater than one quarter of the daily design flow must be provided. The flow equalization zone (between the low water cut-off and high water alarm floats) should be approximately half the daily flow to avoid nuisance alarms. **An override float or override capability must not be used.** A 750 to 1,000 gallon pump tank is usually adequate for a 3 to 4 bedroom residential home. A 500 gallon pump tank is the minimum (e.g., single room cabin or one bedroom home). The size and configuration of the pump tank shall be based on design flow and occupancy and per the NSF listing (as applicable) or State or Local requirements. The pump tank, risers and lids must be watertight.

The dosing rate should be between 7 to 12 gallons per minute per module. The dosing volume should be approximately 5 to 15 gallons per module per dose. For example, a 2 hour dosing interval for a 450 gpd, three module system would result in 12 doses at 37.5 gallons per dose. This equates to 12.5 gallons per module per dose. If the force main is set up to drain back, the drain back volume should be factored into the dosing calculations. A sample pump tank drawdown test calculation is outlined in the table at right.

The diameter of the force main piping is typically 2 to 4 inches. The Puraflo inlet piping manifold diameter is typically 2 inches where

1 and 5 modules are installed or 4 inches where 6 to 10 modules are installed. The outlet piping manifold (where applicable) is typically the same diameter as the inlet piping manifold.

Buoyancy calculations for the septic tank and pump tank should be performed when necessary.

5.5 Biofilter Modules

Effluent from the force main is distributed to the modules via a flow splitting manifold with pressure equalizing orifice plates. Effluent is distributed over the peat fiber media by a pre-installed rectangular grid with large diameter openings that prevent clogging. The effluent charges the grid using the velocity generated by the orifice plates. It is not a pressurized distribution grid.

The site specific design will detail the final effluent dispersal method. Effluent may be either discharged directly to a pad installation or may have a piped outlet for discharge to trench, pressure system, point discharge system or other effluent dispersal method, as applicable.

Modules are pre-assembled depending on the final effluent dispersal method and can have:

Pad system:

- Weep-holes at the base for drainage to a pad system (Blue Module color code)
- Partial weep-holes with a piped outlet on the sealed end diverting effluent to a sample chamber (Green Module color code)

Table 4 Sample Drawdown Test Calculation

Parameter	Inputs & Results
Gallons per inch	20.00
Design flow (gpd)	450
Drainback volume (gals)	25
# Puraflo modules	3
# doses per day	12
Drawdown in tank (inches)	1.25
Time (seconds)	60
"ON" timer setting, secs	95
"ON" timer setting, mins	1.58
Dose volume per module	12.5

Other effluent dispersal methods:

- Piped outlet for connection to another dispersal system (White Module color code)

It is important to specify which modules are needed for a particular design. The type of module is designated by a painted circle on the module lid.

Green module(s) adjacent to a sample chamber have half of their effluent piped from one end of the base of the module through the sample chamber; therefore, there are no weep holes on the end of the module feeding the sample chamber. The chamber essentially provides access to the sample pipes for performance testing purposes. Any uncollected effluent exits the sample chamber through holes in the base or side of the sample chamber.

3 Module Types

Blue Coded Module

Type A: Pad System

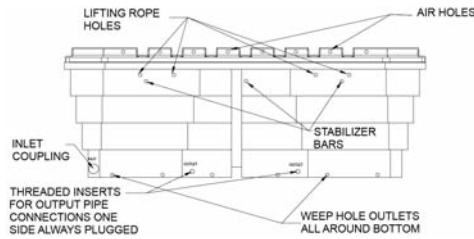

White Coded Module

Type B: Trench System

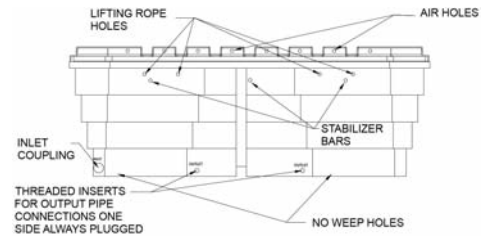

Green Coded Module

Type A: Pad System (for Sample Chamber)

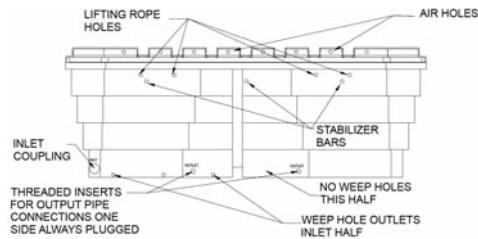

Module Color Coding

- Blue Coded Module: (23) 7/8" dia. holes around bottom area of module
- Green Coded Module: (11) 7/8" dia. holes around half of module for sampling requirements
- White Coded Module: Closed bottom area, no holes in module

Table 5 Puraflo Peat Fiber Biofilter Models

	Standard	Standard with Limestone	NSF 40	Virginia TL-3	Denite	Polishing Filter
	Model Number					
	P150*XX	P150L*XX	P150N*XX	P125TL3*XX	P120Dn*XX	P300L*XX
Design flow, per module (gpd)	150	150	150	125	120	240-300
BOD ₅ loading, per module (lbs/d)	0.3755	0.3755	0.3755	0.3755	0.3755	0.2012
Limestone underdrain (pH)	N	Y	Y	N	Opt	Y
3rd party field testing	Y	N	N	Y	Y	N
NSF Standard 40 protocol	N	N	Y	N	Y	N/A
NSF Standard 40 certified	N	N	Y	N	N	N/A
NSF Standard 245 protocol	N	N	N	N	Y	N/A
NSF Standard 245 certified	N	N	N	N	N	N/A
Mode	SP	SP	SP	SP	MP	SP or MP

All modules use identical components except those with limestone in underdrain have 1 ft³ of limestone substituted for 1 ft³ of granite. Total underdrain stone = ~4.5 ft³ per module

Notes:

- "A" denotes modules with weep holes around the base for discharge directly into a dispersal pad or trench. "B" denotes modules with a set of two, 1" threaded-ports at the base for connection to collection piping that can be routed to a drainfield or to a pump tank/chamber.
- "XX" denotes number of modules and type. Type = "A" or "B". Example: "P150*3A" = 3 Type A modules
- Module type is denoted by color-coded triangle on lid (see "Module Color Coding" above).
- Models with *Limestone* or *NSF 40* model will bear a colored mark with label "L" in addition to blue, green, or white triangle
- NSF 40* models bearing the mark are for residential use only and for flows of 400 to 1,500 gallons per day
- Y = Yes; N = No; Opt = Optional; N/A = Not Applicable; SP = Single Pass; MP = Multiple Pass (Recirc)
- TL-3 = Virginia AOSS Treatment Level 3
- P300L*XX is polishing filter and must be preceded by treatment unit capable of reliably producing white triangle secondary quality effluent (see Polishing Filter Guidelines)

5.6 Cold Weather Conditions

Certain precautions should be taken in extreme cold weather conditions. In particular, the force main should be designed to drain back after each cycle. Also, the module lids will come with foam insulation on the underside of the module lid. All systems must be verified for force main drain back and module lid insulation. Any other accepted standard practice for cold weather conditions should be used per State or Local requirements.

5.7 Life of the Peat Fiber Media

The effective life of the Puraflo peat fiber media is estimated to be 15 years (single pass mode, non-polishing filter mode) under the following conditions:

- System has been operated at or under design flow and loadings
- System has been designed and installed in accordance with Anua guidelines
- System has been maintained in accordance with Anua guidelines, been operated under and ongoing service contract and is in compliance with all Administrative Authority permit conditions

5.8 Final Dispersal System

The final dispersal system must be designed in accordance with State or Local regulations and Anua guidelines.

6.0 System Layout & Components

6.1 Schematic of Puraflo System Components

Part No.	Description
1	Septic Tank
2	Effluent Filter
3	Sewer Line
4	Riser and Lid
5	Pump Tank
6	Pump
7	Floater
8	Ball Valve
9	Union Disconnect
10	Timed Dose Control Panel
11	Force Main
12	Puraflo Module(s)
13	Stone Pad

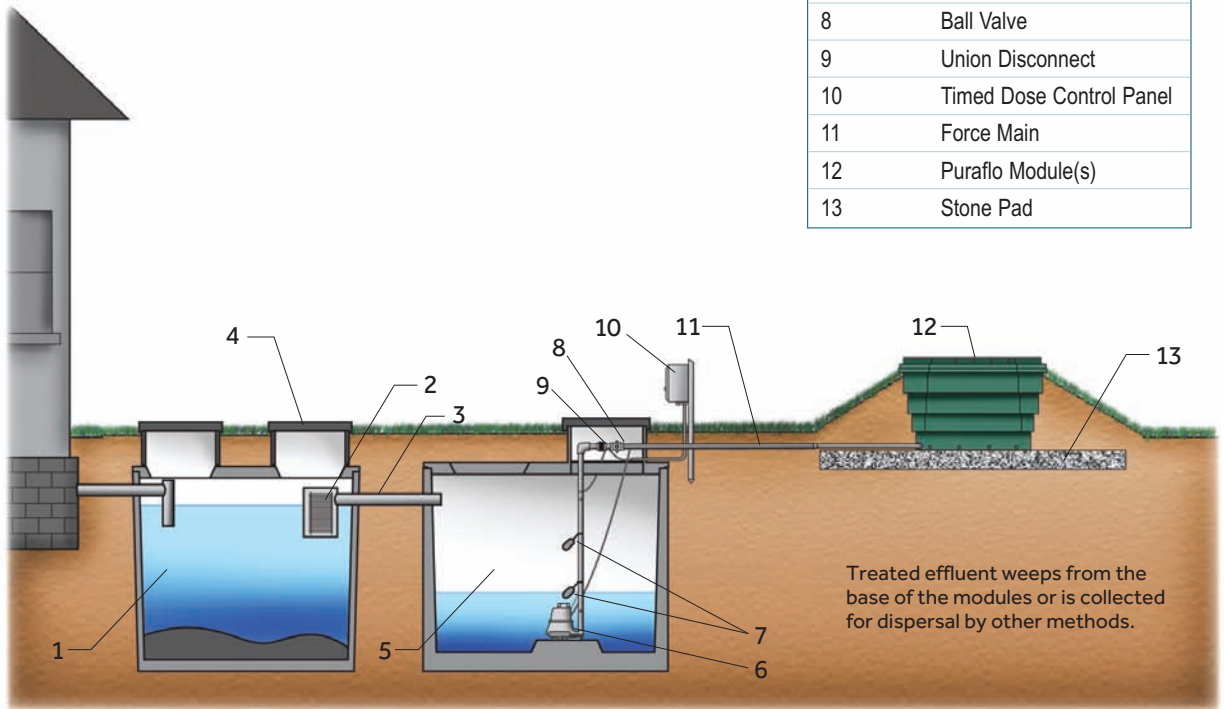

6.2 Specification of Puraflo Module

Max Treatment Capacity per Module:

- 150 gpd (residential)
- 120 gpd (commercial or recirculation)
- 240-300 gpd (polishing)

Module Length: 7' 1"

Module Height: 2' 6"

Module Width: 4' 6"

Module Weight: ~1800 lbs



7.0 Installation Requirements

Installation of the Puraflo system is straight forward and can usually be completed in less than a day.

- **Warning:**
- Use recognized, safe lifting techniques to off-load and set modules.
- Ensure all lifting equipment is clear of overhead obstructions such as power lines, trees, rooftops or any other construction.
- Place the lifting equipment on solid, stable ground.
- Use a four-point sling or equivalent (see Fig.2).

The contractor/installer is required to provide the following:

- Mechanical excavator (backhoe) with operator.
- An electrician or person qualified to undertake the work in accordance with State or Local regulations (the electrician will be required to connect the pump and alarm to the control panel, set timer as required, and connect the control panel/junction box with the main power supply). Provide and supervise the installation of the underground cable from the control panel/junction box to the main circuit board.
- Provide gravity and force main piping and fittings per design. Piping under pressure must be PVC Schedule 40 or equivalent.
- Clean stone (3/4 to 1-inch) as required.
- Additional/imported fill material (typically not sand) and topsoil as required.
- Labor as necessary to install the system.
- Necessary supervision to ensure the system is installed per design.

8.0 Electrical Requirements

An independent electrical circuit to power the control panel (115/230 volts and 20 amps typical) must be provided. These requirements may change by State or Local code or when a duplex panel, a larger pump or a high head pump is required per design. Please refer to site specific design to verify electrical requirements noting the requirement for 115 or 230 volts and the amps rating required for the controls and the pump.

Figure 2 Module Off-loading



9.0 Sequential Installation Procedure

9.1 Site Clearance

- Clear site vegetation as required (minimize site disturbance).
- Provide sufficient access to proposed system.

9.2 Septic Tank

- Supply and install septic tank and sewer pipe from the dwelling in accordance with applicable State or Local regulations. The septic tank must be watertight against ground and/or surface water infiltration and exfiltration.
- Install septic tank on stable, compacted ground and backfill with suitable material as recommended by the manufacturer.
- Fit an effluent filter (1/32" specification) on the outlet pipe.
- Install water tight risers over inlet and outlet access ports to provide access for filter maintenance, septage removal, etc.
- Backfill and grade around the septic tank to prevent infiltration of surface water.
- See Appendix 1: *Typical Septic Tank Detail*.

9.3 Pump Tank Installation

- Supply and install the pump tank in accordance with applicable State or Local regulations. The pump tank must be watertight against ground or surface water infiltration and/or exfiltration.
- Install pump tank on stable, compacted ground and backfill with suitable material as recommended by the manufacturer.
- Install gravity main from the septic tank to the pump tank in accordance with applicable State or Local regulations.
- Excavate a trench, typically 18 inches deep, from the pump tank to the location of the modules. In colder climates the force main may be buried deeper (below frost line).

- Place sufficient risers on top of the pump tank to reach slightly above grade level. It is extremely important to ensure a water-tight seal between the pump tank and the first riser and between individual risers.
- All connections/seals should be made water tight in accordance with manufacturer's recommendations.
- Backfill, compact and landscape around the pump tank inlet/outlet pipes and electrical cable points of entry. Ensure suitable backfill material is used in accordance with manufacturers instructions.

9.4 Pump Fittings and Piping

- Place the base of the pump 4 to 6 inches above the base of the pump tank.
- Glue required length of PVC force main into the fitting at the outlet of the pump. Install the required fittings (check valve, union, ball valve, etc. as required by the design). Note: in most cases a 2 inch forced main is specified so a bushing (1 1/2 inch x 2 inch) may be required to connect the internal pump tank piping to the pump. In some cases, the force main may be designed to drain back and a drain back hole will be required above the check valve. Install an air vent hole when required and an anti-siphon hole if the module grid is lower than the liquid level in the pump tank.
- Floats are generally used however other suitable level devices may be installed. Install on/off float typically at pump level (to ensure that the pump is kept submerged). Install alarm float with 1/2 day storage above the on/off float. Strap floats to force main or separate stand pipe or hang from bracket.
- Install the force main in the trench from the pump tank to the modules. Backfill trench once the line is correctly installed and connected. Be careful not to damage the installed force main line with heavy vehicle activity.
- See Appendix 1: *Typical Septic Tank Detail*.

9.5 Puraflo Installation

The site specific design will detail the final effluent dispersal method. Effluent may be either discharged directly to a pad installation or may have a piped outlet for discharge to trench, pressure systems, point discharge systems or other effluent dispersal methods, as applicable. The model numbers are identified as A for a pad installation and B for a piped outlet installation.

Type A – In-Ground Pad Installation

See Appendix 2:

Type A: In-Ground Pad Configuration

- Excavate a pad area (as specified in the design), making sure to maintain the required vertical separation distance between the bottom of the pad and any vertical restrictions such as seasonal high water table. The pad bottom must be level.
- Fill and level the excavated area with clean stone (3/4 to 1 inch, see Appendix 8) in accordance with the design, to a minimum depth of 6 inches.
- Position the modules on the stone pad area. Connect the force main to the module inlet coupling (incorporating a flexible pipe).
- Fit the sample chamber pipe to the outlet from the side of the green color coded module that does not have weep holes in the base. Insert the sample chamber pipe so that it extends 3 inches into the sample chamber and at least 5 inches off the base of the sample chamber. The sample chamber is pre-drilled with 7/8 inch holes in the base/side of the sample chamber to allow effluent to enter the pad foot-print area when samples are not being collected. The top of the sample chamber should be positioned at approximately the same level as the top of the modules.
- Backfill with stone around the modules to a height of 6 inches above the weep holes around the base of the modules when applicable.
- Cover the remaining exposed stone surface around the outside of modules with a suitable filter fabric. This prevents smaller soil particles from being washed into and subsequently clogging the foot-print area.
- Reinstall with suitable backfill and topsoil to finished design level.
- Ensure that the Puraflo lids are securely fastened.

Type B – Piped Outlet Installation

See Appendix 2: *Type B: Final Dispersal Separate from Module Configuration*

- For piped outlet installations the pad area's primary function is to level and support the modules.
- Excavate a pad area (as specified in the design). The pad bottom must be level.
- Fill and level the excavated area with clean stone (3/4 to 1 inch) in accordance with the design, to a minimum depth of 6 inches.
- Position the modules on the stone pad area. Connect the force main to the module inlet coupling (incorporating a flexible pipe). Construct the outlet pipework to the sampling chamber and to the final dispersal system in accordance with the design.
- Backfill with stone around the modules to a height of 6 inches above the drain holes on the side of the modules.
- Reinstall with suitable backfill and topsoil to finished design level.
- Ensure the Puraflo lids are securely fastened.

Type A or B – Additional Conditions for Dn (recirculation) Model

- One brass discharge fitting on the bottom of both sides of module (two total equaling half of module hydraulic loading) must be plumbed to return to the front end (first compartment) of septic tank.
- The return line from the modules to the septic tank must be properly sloped for gravity flow. If the Puraflo effluent can not return by gravity to the septic tank, a small basin with on-demand pump could be used.
- Return line size must meet local plumbing code requirements.
- For Type A pad dispersal systems, all modules must be Green coded modules.
- For Type B piped outlet dispersal systems, all modules must be White coded modules.

9.6 Electrical Connections

- Select a location for the electrical control panel near the pump tank or home.
- Install the cable between the power source and the control panel in accordance with State or Local regulations.
- Place the electrical power cable(s) in the trench/conduit (do not stretch cable). Connect each cable coming from the equipment in the pump tank in accordance with the wiring diagram located on the door of the control panel (a typical wiring schematic is detailed below). The cable between the pump tank and the control panel is to be installed in conduit and include the appropriate conduit seal. Reinstall area.
- Connect the electrical power cable(s) to an independent electrical power supply of the specified voltage (usually 115 volts), terminating in a socket or junction box protected by an M.C.B. as required (usually 20 amps). If a duplex control panel or high head pump is required the voltage and amperage requirements may increase.
- Input timer settings in accordance with design.
- Test and commission pump operation, start/stop conditions and alarms.
- All electrical work shall be done in accordance with State or Local regulations and/or building codes.

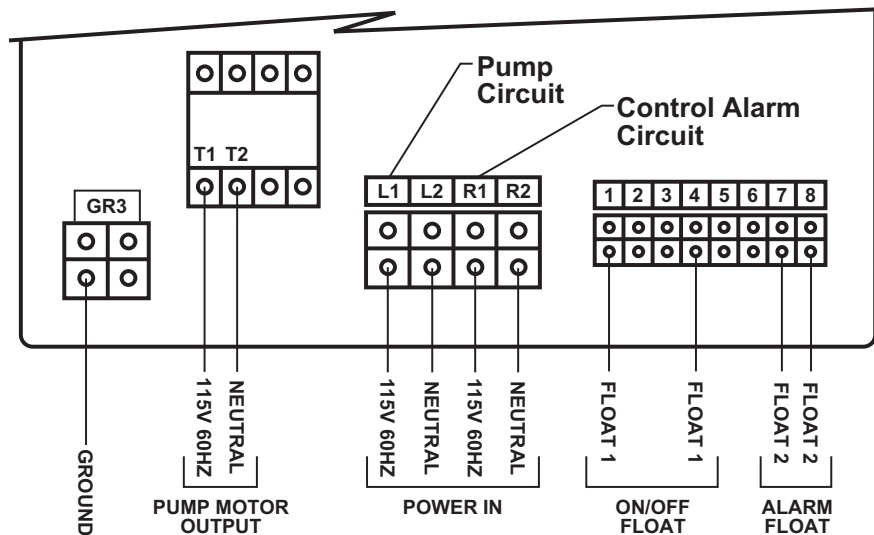

Typical Wiring Schematic for a simplex pump system. Please refer to the inside of the Control Panel for the actual wiring diagram and specifications.

9.7 Spare Parts

Spare or replacement parts can be obtained from the manufacturer of the component or Anua if they need to be replaced.

9.8 Site Restoration

- The modules must be installed at grade or above grade with the ground landscaped to divert storm water away from the modules.

- Backfill around modules to a height just under the lid of the modules.

Grade the backfill back to the existing ground level on a slope no steeper than 2:1.

Backfill should be suitable, loose, workable material.

Compact backfill sufficiently to counteract settlement.

Ensure a 6 inch minimum cover over drainfield stone where applicable.

The final layer (6 inches) of fill material should be suitable topsoil capable of supporting vegetative growth.

- Grass seed and straw the sloped backfill area and any trench excavation lines with a suitable indigenous seed variety. In some cases, sodding for immediate stabilization may be specified.
- PROVIDE EROSION PROTECTION AS REQUIRED PER DESIGN PLAN.

Appendix 1 Typical Septic Tank & Pump Detail

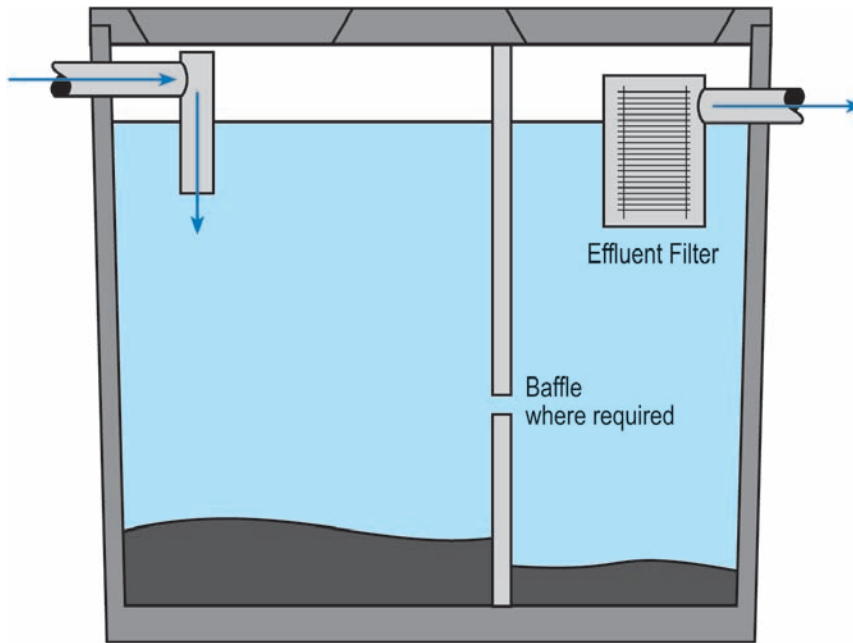

NOTES:

1. Septic tank must be approved by the State or Local regulatory authority.
2. Sizing, design, construction and installation must conform to applicable regulations.
3. For polishing filter model, Puraflo module(s) will be preceded by a treatment unit, in lieu of a septic tank, designed to meet secondary effluent standards. See *Puraflo Polishing Filter Guidelines*.

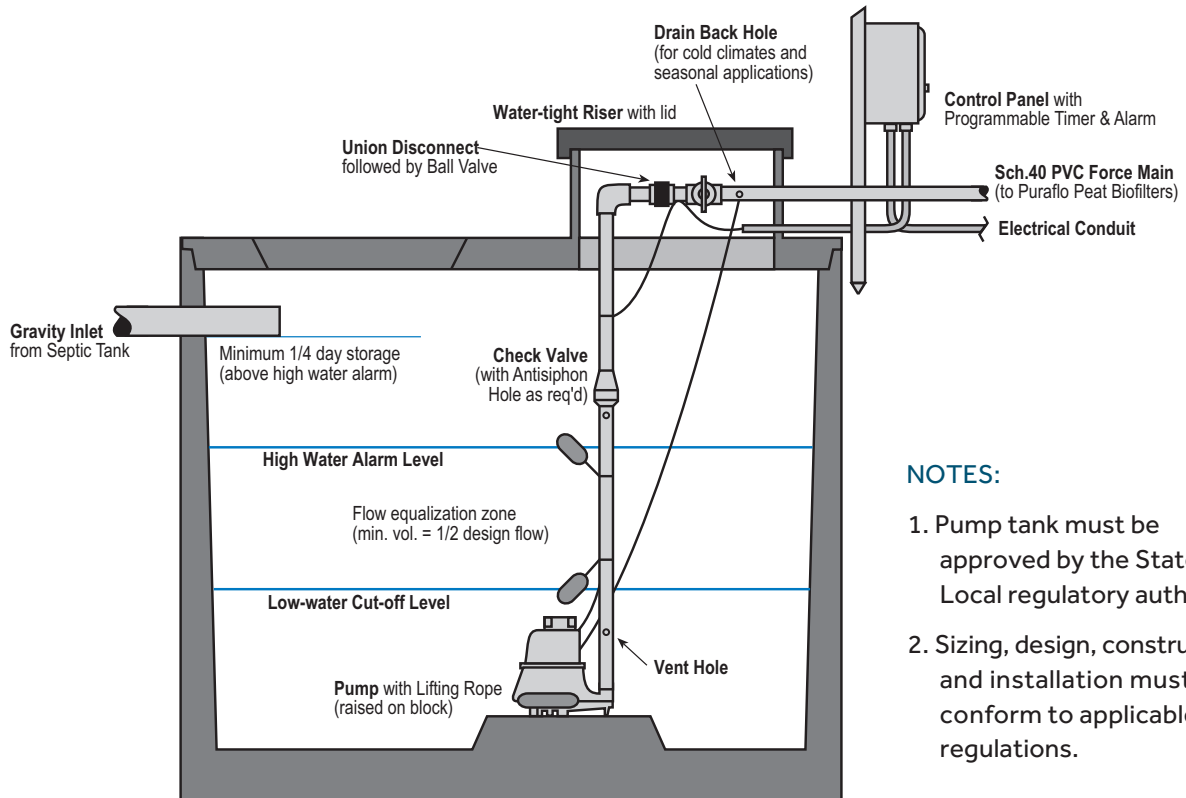

NOTES:

1. Pump tank must be approved by the State or Local regulatory authority.
2. Sizing, design, construction and installation must conform to applicable regulations.

Appendix 2 Type A & Type B Installation

Type A – Pad Installation

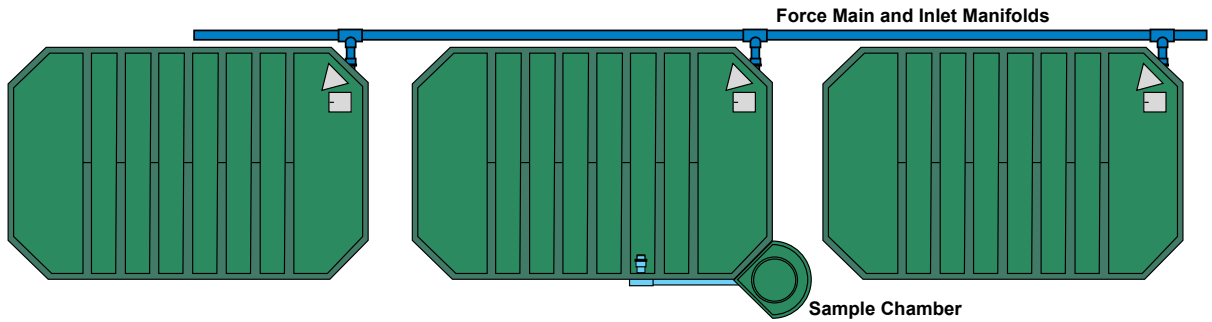

Blue coded modules with weep holes and one green coded module with sampling chamber, drain into a stone pad for final treated effluent disposal. Pad dimensions can be selected to match site conditions and modules can be installed side-by-side as well as end-to-end (as shown above)

Type B – Piped Outlet Installation

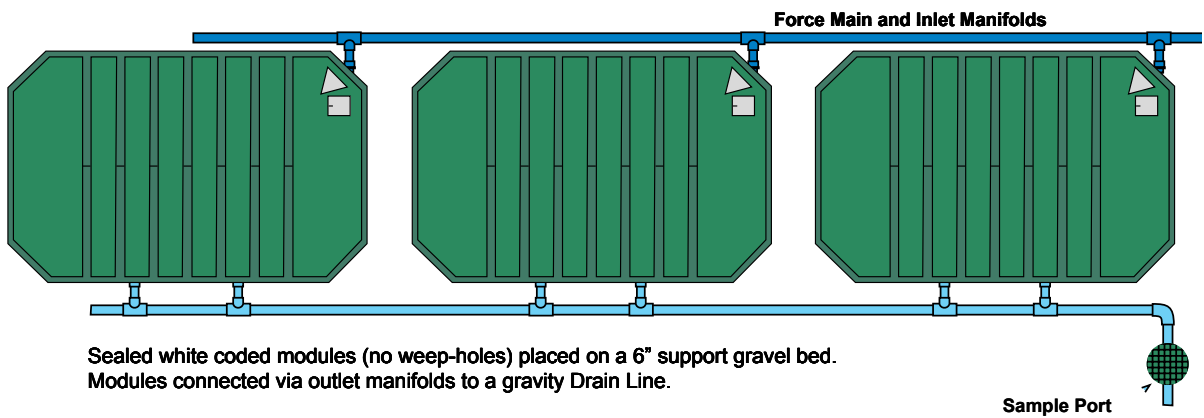

Sealed white coded modules (no weep-holes) placed on a 6" support gravel bed. Modules connected via outlet manifolds to a gravity Drain Line.

Sample Port

Appendix 3 Assembled Module Detail

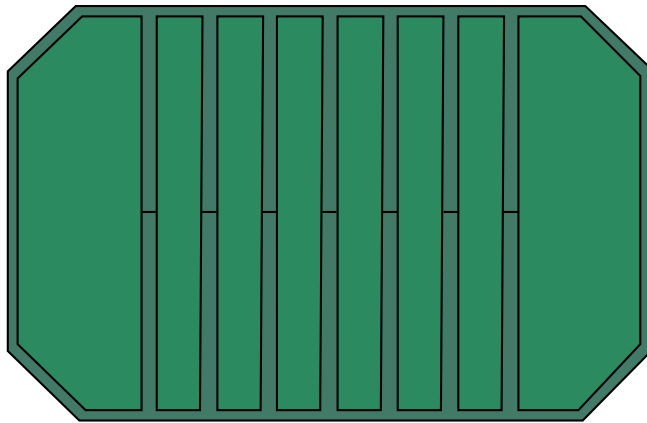

Plan View

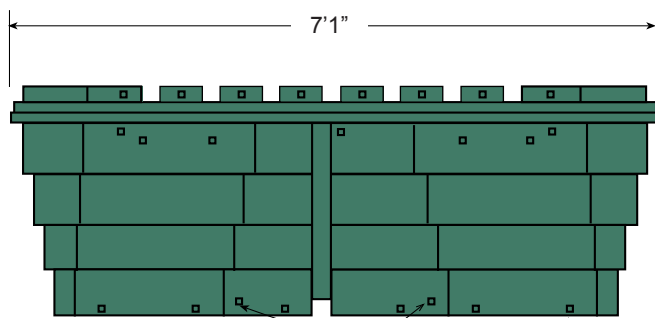

4 - 1" Threaded inserts

Sealed modules are without weep holes

Elevation View

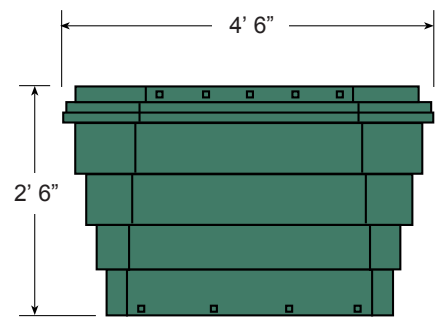

End View

Appendix 4 Module Grid Detail

NOTE:

All piping and fittings must be a minimum Schedule 40 Rated

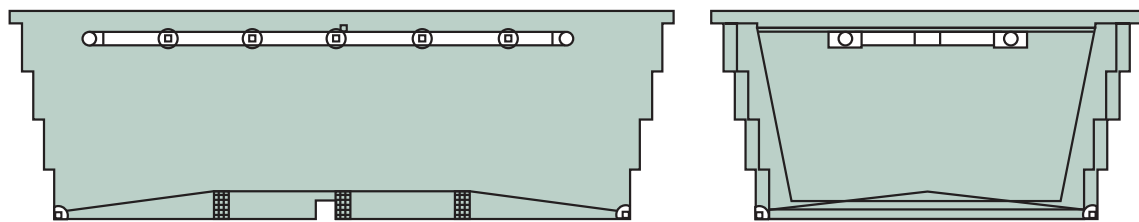
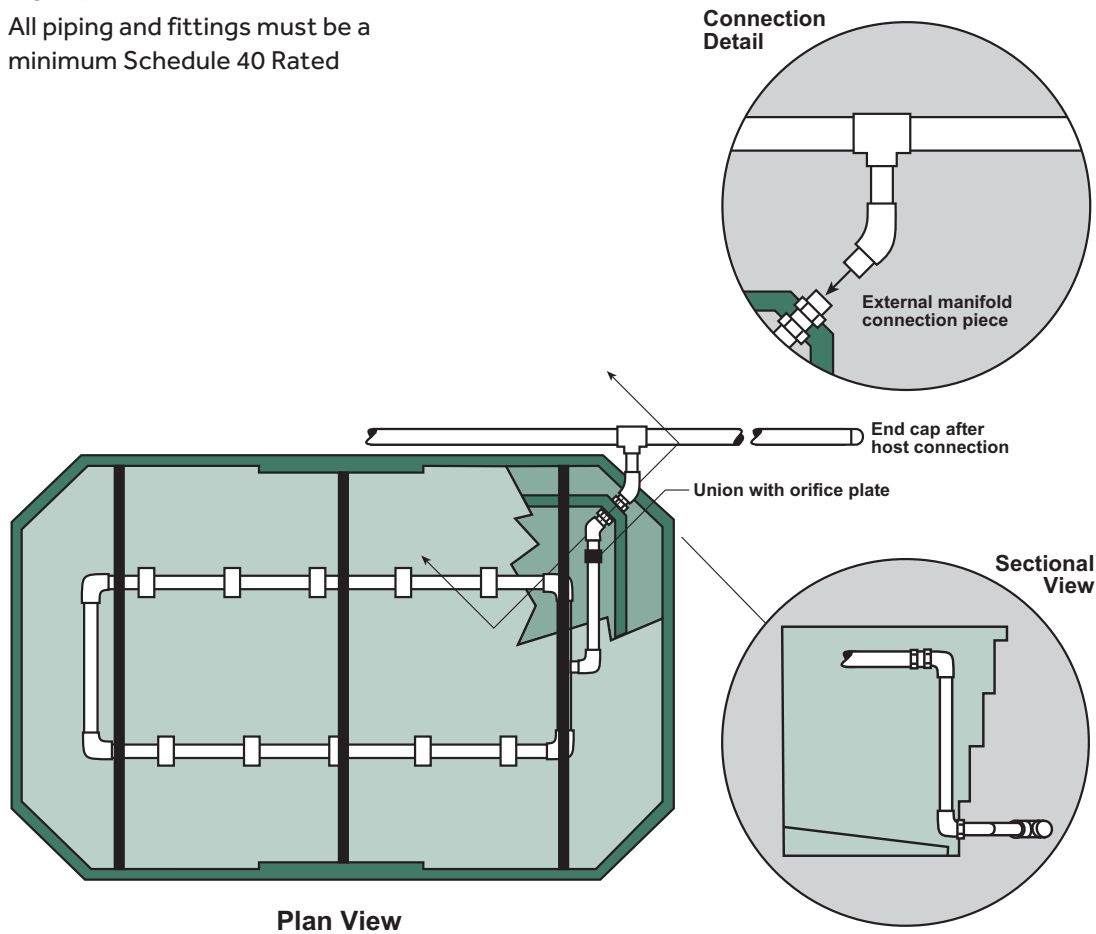

Sectional Elevation View

Sectional End View

Appendix 5 Sample Chamber Detail

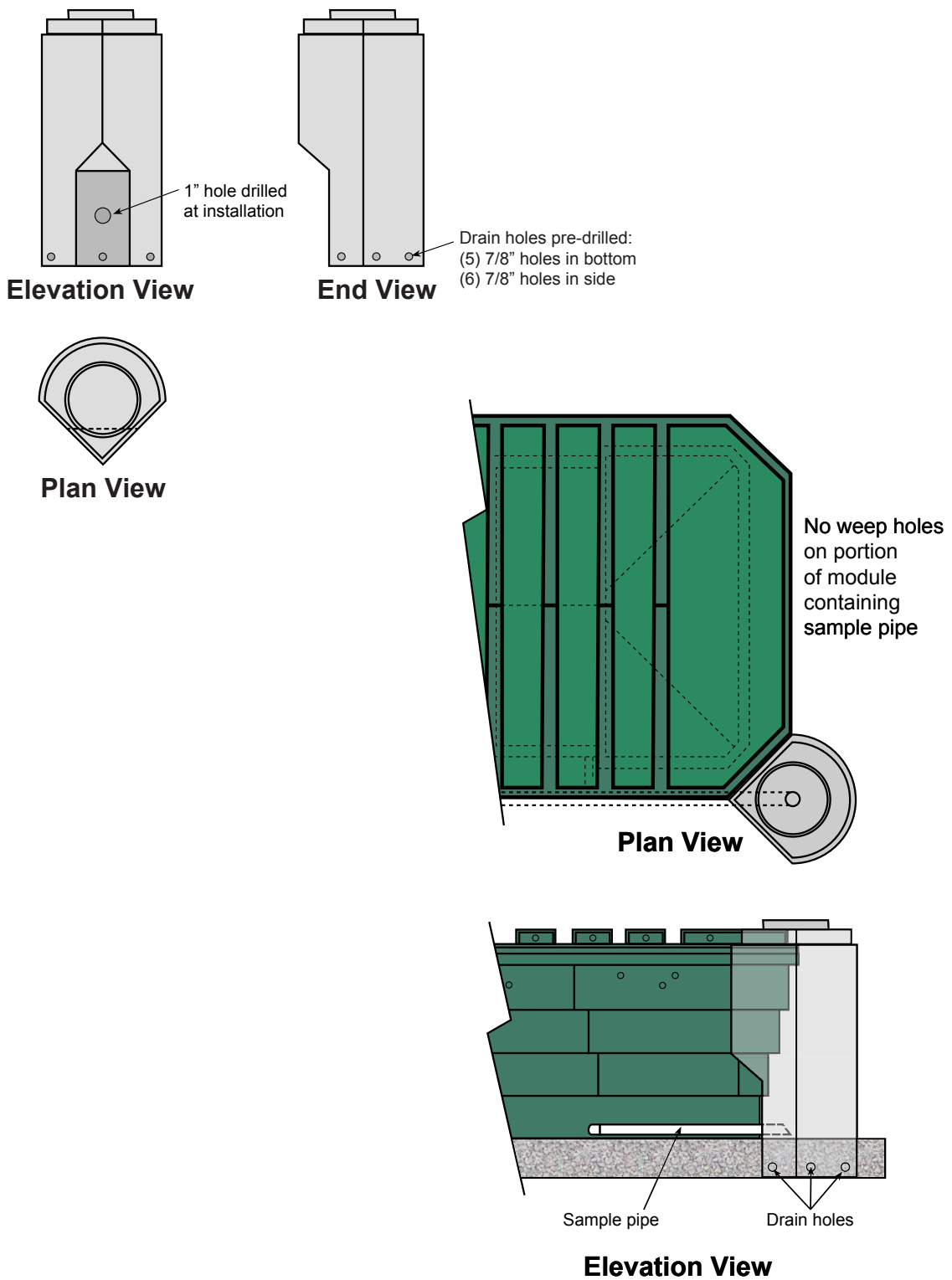

Appendix 6 Module Pictures

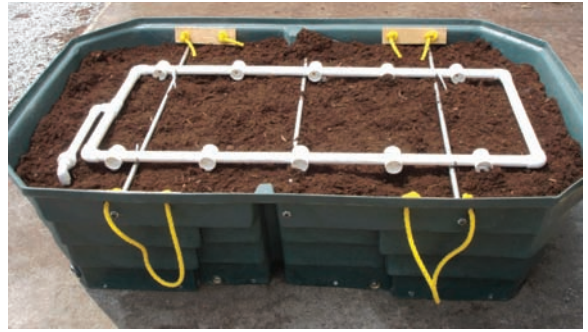

NOTE: Pipe is colored for emphasis

Appendix 7 Information Needed for the Drawdown Test

- Pump tank gallons per inch
- Design flow (gallons per day)
- Drainback volume (gallons), if applicable for cold weather situations
- # of Puraflo modules
- # of doses per day (typically 12)

Drawdown Test Procedures

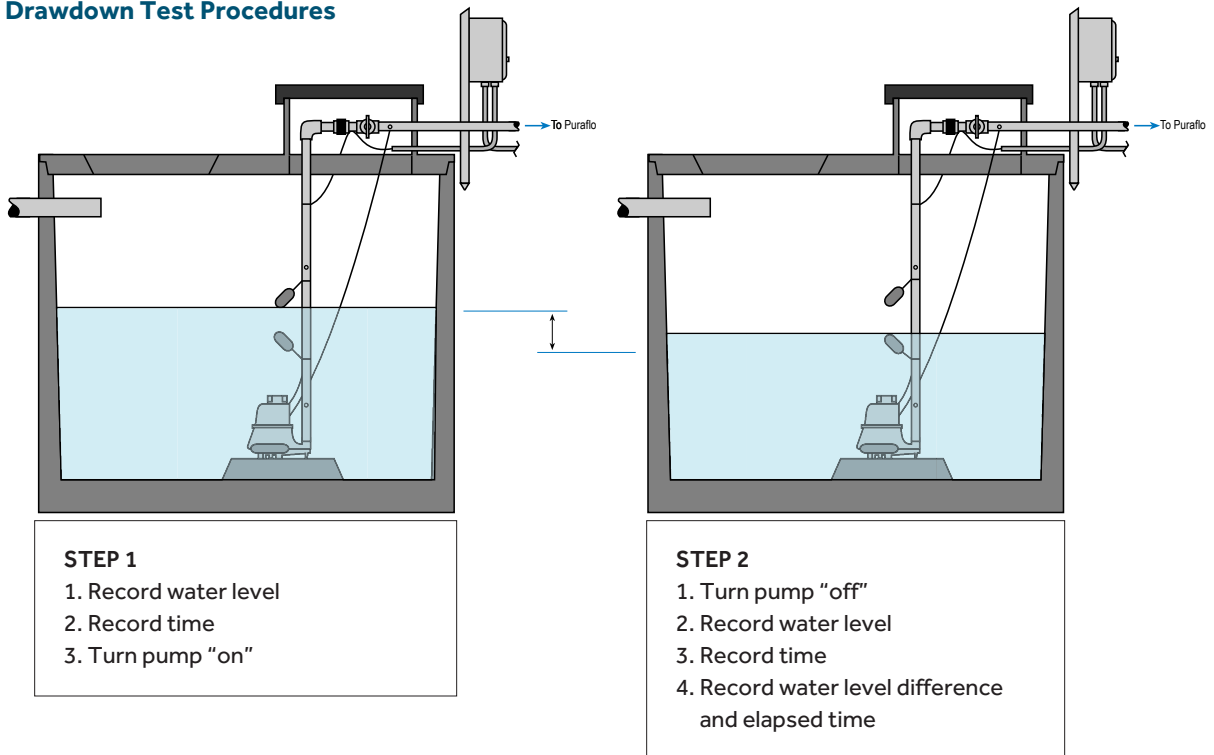

Timer Setting & Module Dose Volume Based on Drawdown Test

Example Parameters

- | | |
|-------------------------------|--------------------------|
| ■ Pump tank gallons per inch: | 20 gallons |
| ■ Design flow: | 450 gpd (3 bedroom home) |
| ■ Drainback volume, per dose: | 5 gallons |
| ■ # of Puraflo modules: | 3 modules |
| ■ # of doses per day: | 12 doses |
| ■ Water level difference: | 2 inches |
| ■ Elapsed time: | 1 minute |

Example Timer Setting Step 1

Multiple Drainback volume, per dose by # of doses per day 5 gallons x 12 doses = 60

Example Timer Setting Step 2

Add Design flow & Total from Step 1 450 gallons + 60 gallons = 510

Example Timer Setting Step 3

Divide the Total from Step 2 by # of doses per day 510 ÷ 12 doses = 42.5

Example Timer Setting Step 4

Multiply the Total from Step 3 by Elapsed time 42.5 x 1 minute = 42.5

Example Timer Setting Step 5

Multiply the Pump tank gallons per inch by the Water level difference 20 gallons per inch x 2 inches = 40

Example Timer Setting Step 6

Divide the Total from Step 4 by the Total from Step 5 42.5 ÷ 40 = 1.06 minutes
 1.06 minutes for "on" timer setting or
 1.06 minutes x 60 seconds/minute = 63.6 seconds (round-up to 64 seconds)

Example Timer Setting Step 7

Divide the Hours in a day by the # of doses per day 24 hours ÷ 12 doses = 2 hours for "off" timer setting

Example Module Dose Volume Step 1

Divide the Design flow by the # of doses per day 450 ÷ 12 = 37.5

Example Module Dose Volume Step 2

Divide the Total from Step 1 by the # of Puraflo modules 37.5 ÷ 3 = 12.5 gallons/dose per Puraflo module

Appendix 8 Criteria for Dn (recirculation) Model for Denitrification

Puraflo Dn is a typical Puraflo Peat Fiber Biofilter system which provides enhanced denitrification through recirculating 50% of the treated effluent back to the front-end of the septic tank. Flow proportioning is accomplished through simple adaptations to external plumbing. In recirculation mode, each module is rated for domestic strength at 240 gallons per day total hydraulic loading equivalent and 120 gallons per day forward

flow. In 2011, Dn was tested to NSF/ANSI Standard 40 Class 1 and NSF/ANSI Standard 245 Class 1 by the Soil Science Department, College of Agriculture and Life Sciences, North Carolina State University at TZ Osborne Water Reclamation Facility in Greensboro, North Carolina. North Carolina State University published the final test report in March 2013. The Dn model is not certified or listed by NSF International.

Table 7 Puraflo Dn Model

Parameter	Dn Specific Criteria
Septic tank sizing	Daily design flow (gpd) ÷ 0.36
Pump tank sizing	Daily design flow (gpd) ÷ 0.36
Dose volume, per module	5 - 15 gals per dose, max
Dose rate, per module	7 - 12 gpm per module
Timer "off"	1 - 2 hours

Note:

For criteria not specifically noted in Table 7, follow criteria outlined in other sections of this manual.

Sample Chamber Dn Detail

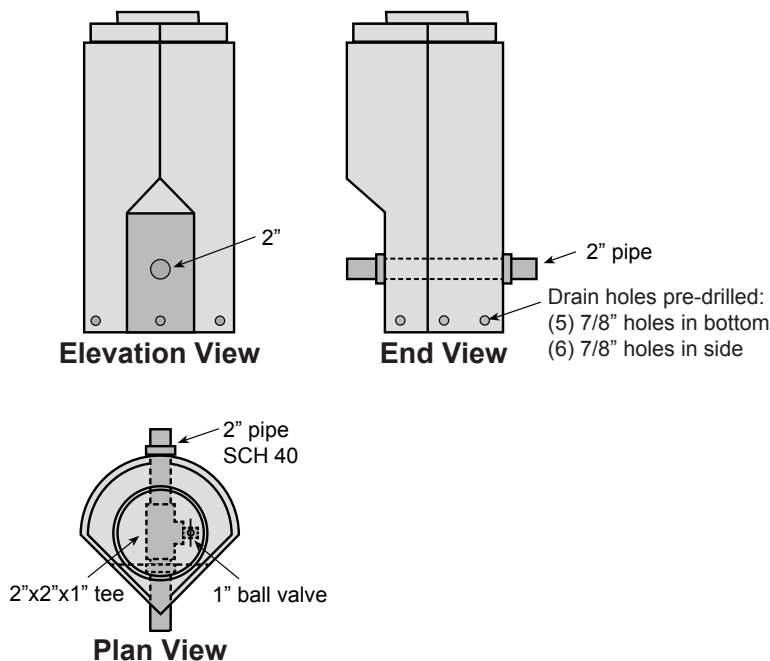

Typical Configuration Puraflo Dn Type A – Pad

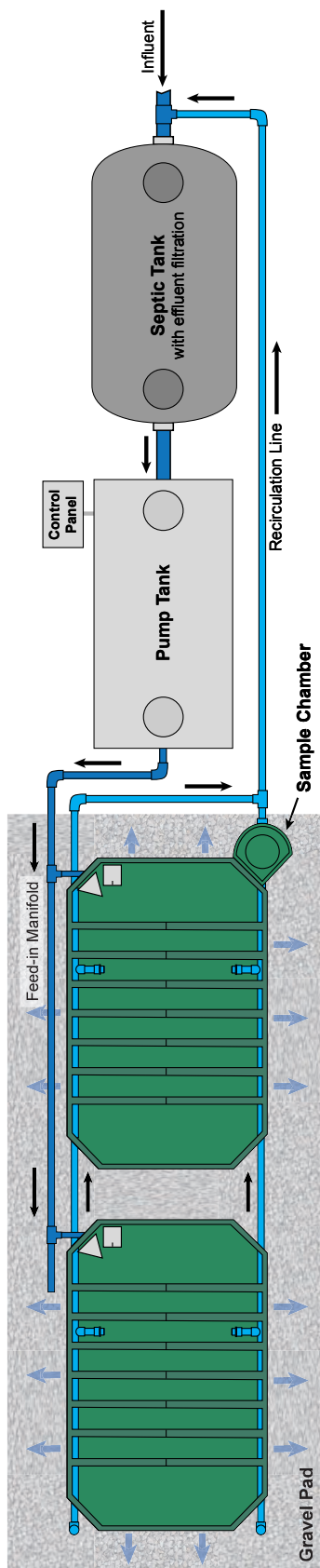

Typical Configuration Puraflo Dn Type B – Piped Outlet

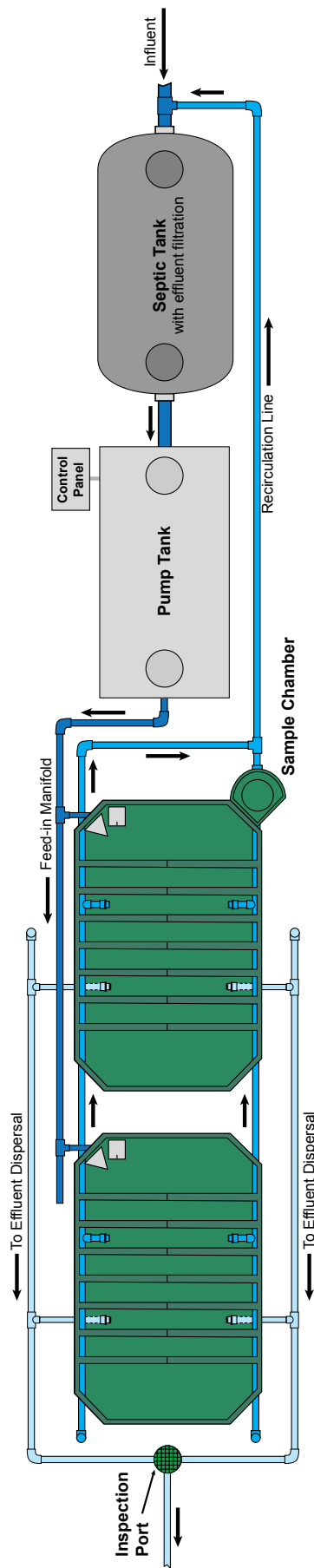

Appendix 9 Additional Effluent Dispersal Criteria

Type A System: Puraflo Modules Combined with IN-GROUND PAD Dispersal

- Refer to section 5 and 9 of this manual.
- All components used in conjunction with the Puraflo Peat Fiber Biofilter must comply with all applicable State or Local rules and codes.
- The septic tank shall be sized according to State or Local code.
- An effluent filter/screen shall be placed on the outlet of the septic tank that meets the requirements of Section 5.3 of this manual.
- The pump tank shall be sized according to State or Local code.
- Calculations can be done with the Microsoft Excel Design Sheet.
- The in-ground pad dispersal area may be sized per the soil texture hydraulic loading (BOD=30) in Table 4-3 of the USEPA 2002 Onsite Wastewater Treatment Systems Manual or Anua criteria.
- The length and width can be sized using the Kaplan (1991), Allen (1980), or Poeter (2005) water mounding equations or linear loading rates in the Tyler (2001) Table ≤ 30 mg/l BOD₅.
- The bottom of the stone dispersal area shall maintain a minimum vertical separation distance from limiting conditions per State or Local requirements or 1 foot (6 inches to seasonal high water table). Seasonal high water table vertical separation distance may be reduced to greater than 0 inches and less than 6 inches if approved by the local board of health or administrative authority. In situ soil must be a minimum of 6 inches or per hydraulic modeling.
- The dispersal aggregate shall be clean stone (3/4 to 1 inch). The stone shall be washed with not more than 5% passing the No. 200 (75 μ m) sieve as determined by ASTM C117, "Test Method for Material Finer than 75- μ m (No. 200) Sieve in Mineral Aggregates by Washing" and shall be durable with a hardness of 3 or greater on the Moh's Scale of Hardness. Alternatively, gravelless technologies may be utilized instead of stone.
- The dispersal material shall be leveled to a depth of 6 inches.
- The Puraflo modules shall be placed on the dispersal material so that they are evenly spaced from the sides of the distribution bed and end of the distribution bed with even spaces between each module and the ends of the dispersal area. The minimum spacing from the end of the dispersal material to module end is 1 foot. For spacing calculation, see example below. The modules shall consist of one green coded module and the remainder blue coded (modules may be shipped from the factory as white coded that can be field modified to blue or green by drilling the appropriate number of 7/8" holes on predetermined spots on the modules). If modules are field modified it is the responsibility of the installer to change the color code on the lid of the module.

Sample spacing calculation

3 modules, each module is 4.58'W x 7.08'L
 Dispersal pad is 10'W x 96'L
 Total module L = 3 x 7.08' = 21.24'
 Spacing between modules & ends = 96' - 21.24' = 74.76'
 = 74.76' / 2 (in-between modules) + 2 (ends) = 74.76' / 4
 = 18.69' between modules & from ends

- The Puraflo modules shall be level from side-to-side and end-to-end.
- Connect the force main to the module inlet coupling (incorporating a flexible pipe). Note sizing requirements in Section 5.3 of this guide. The manifold connection shall be configured like the illustration in Appendix 2 and 4 of this guide and shall pass the last module by a minimum of six inches and be capped. It is recommended that a clean-out be brought to finished grade.
- Distribution media shall be placed at a level to completely cover the distribution holes on the side bottom of the Puraflo modules.
- An Anua specified sample chamber shall be placed on one of the outlet connections of a green color coded module for sampling of effluent.
- Once the Puraflo modules are installed and all connections have been made, the distribution media shall be covered with a geotextile fabric.

- The system shall be backfilled with sandy to loamy soil material and topsoil to the bottom lip of the Puraflo modules.
- Additional design considerations:

For slowly permeable soils, designers must use professional judgment to ensure effluent absorption into the soil and that other potential issues are mitigated, such as water mounding. For most soils, absorption and water mounding are not issues, even with as little as 1 foot of minimum vertical separation. Also, Converse and Tyler (2000) note, "The design loading rates are based on 150 gpd/bedroom resulting in 450 gpd for a 3 bedroom home. If the mound, as well as other soil based units, is loaded at 450 gpd on a regular basis, it will likely fail. The daily average flow is expected to be no more than about 60% of design or 270 gpd."

The effluent spread, as depicted in the diagram below, and water mounding height can be calculated using the Kaplan (1991) equations below:

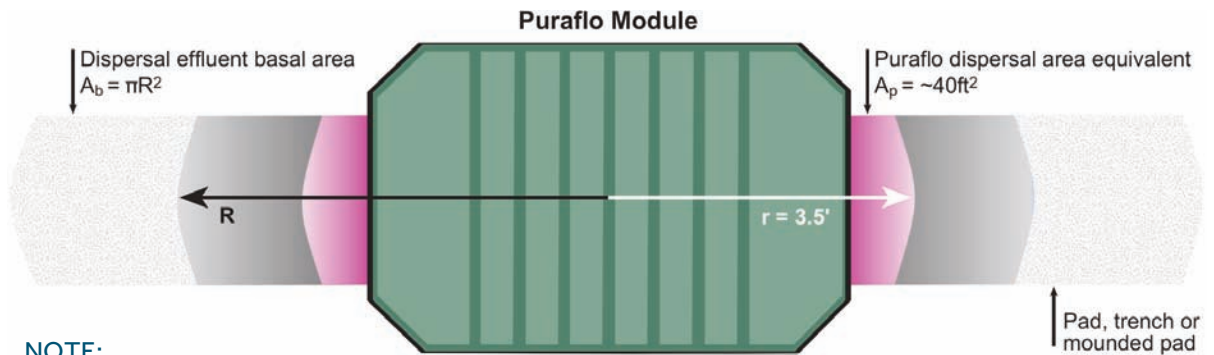

NOTE:

In-ground effluent movement will occur within gravel layer.
 For mounded applications, movement will occur through gravel and sand along contour.

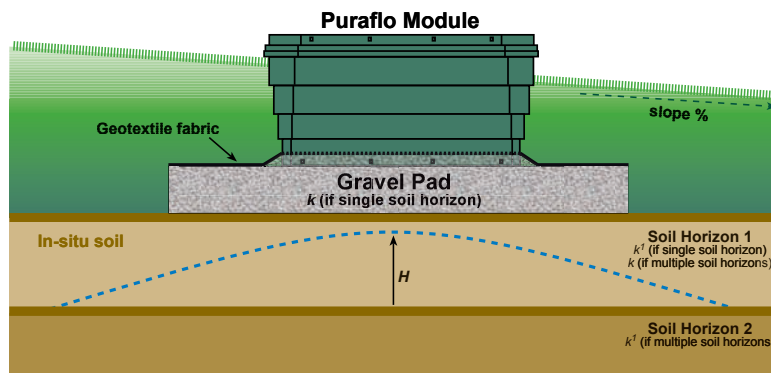

In-ground Pad System Diagram (typical)

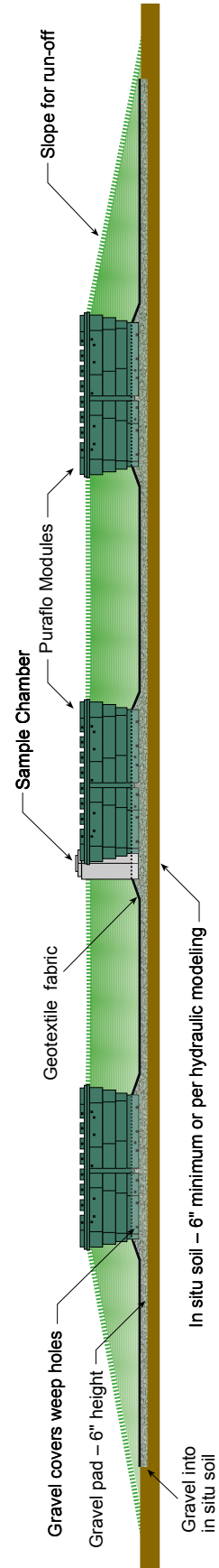
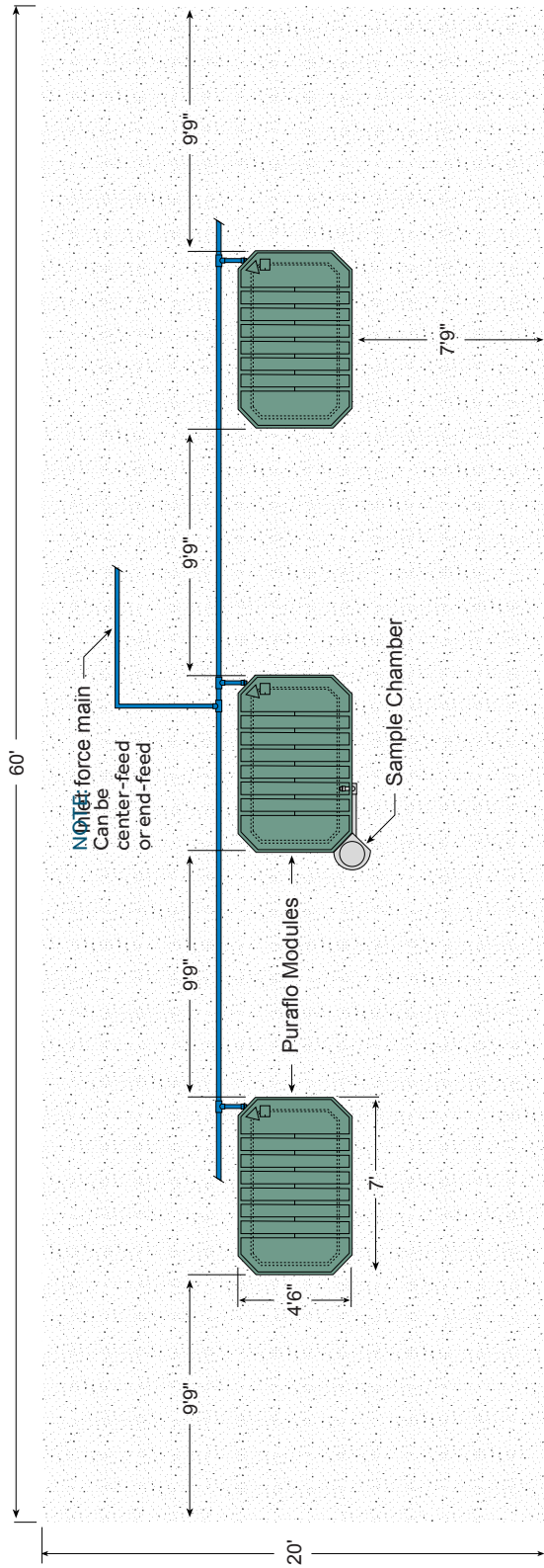

Type A System: Puraflo Modules Combined with MOUNDED PAD Dispersal

Conditions

- Refer to section 5 and 9 of this manual.
- All components used in conjunction with the Puraflo Peat Fiber Biofilter must comply with all applicable State or Local rules and codes.
- The septic tank shall be sized according to State or Local codes.
- An effluent filter/screen shall be placed on the outlet of the septic tank that meets the requirements of Section 5.3 of this manual.
- The pump tank shall be sized according to State or Local codes.
- Calculations can be done with the Microsoft Excel Design Sheet.
- The bottom of the stone dispersal area shall maintain a minimum vertical separation distance from limiting conditions per State or Local requirements or 1 foot (6 inches to seasonal high water table). Seasonal high water table vertical separation distance may be reduced to greater than 0 inches and less than 6 inches if approved by the local board of health or administrative authority. In situ soil must be a minimum of 6 inches or per hydraulic modeling.

Site limitations and Modifications

- Mounded pads shall be oriented parallel to natural surface contours and shall be sited to avoid natural drainage features and depressions that may hold surface water. A design plan shall address surface water diversion as needed.
- An interceptor drain may be used upslope of a mounded pad soil absorption component to intercept the horizontal flow of subsurface water to reduce its impact on the down gradient mounded pad component.

- A mounded pad soil absorption component shall not be sited on a slope greater than 25 percent unless the design plan includes special installation criteria.
- Sites with boulders or numerous trees are less desirable for a mounded pad soil absorption component. Such conditions shall be avoided or the design plan shall increase the basal area to compensate for losses due to boulders or flush cut trees and shall include special instructions for the basal area preparation under such conditions.

Site and Soil Information

- Site information shall include a description of landscape position, slope, vegetation, drainage features, rock outcrops, erosion and other natural features; and documentation of any relevant surface hydrology, geologic and hydrogeologic risk factors for the specific site or in the surrounding area that may indicate vulnerability for surface water and ground water contamination.
- Soil Information shall include identification of depth to limiting conditions including but not limited to water table and rock strata, and a description of soil texture, consistence, and structure, including shape and grade.

Design Criteria

- The mounded pad basal area may be sized per the soil texture hydraulic loading (BOD=30) in Table 4-3 of the USEPA 2002 Onsite Wastewater Treatment Systems Manual or Anua criteria.
- The length and width can be sized using the Kaplan (1991), Allen (1980), or Poeter (2005) water mounding equations or linear loading rates in the Tyler (2001) Table ≤ 30 mg/l BOD₅.
- Location must be comply with State of Local codes.

Sand Fill

- The mounded pad sand fill depth shall be determined based on the depth to the limiting conditions. The sand fill depth shall not exceed two feet and shall not be less than four inches. The loading rate for the sand fill material shall not exceed 2.0 gpd/ft².
- Natural sand is defined as naturally deposited silica based sand not manufactured by mechanical processing such as the crushing of rock or coarse aggregates.
- Sand fill for the mounded pad must be concrete sand meeting the gradation requirements of ASTM C33 provided not more than 5% passes the No. 100 sieve and not more than 5% passes the No. 200 sieve as determined by ASTM C117, "Test Method for Material Finer than 75- μ m (No. 200) Sieve in Mineral Aggregates by Washing".
- A comparison of sand application rates from various regulatory authorities is in the table below.

Table 6 Sand Application Rates Comparison

Regulatory Authority	Gradation	Additional Gradation Requirements	Effective Size	Uniformity Coefficient	Sand Application Rate Gpd/ft ² (≤ 30 mg/l BOD ⁵)
Iowa	ASTM C33 or IDOT No.1	Sand fill must not have more than 20% (by weight) material that is greater than 2mm in diameter (coarse fragments), which includes stone, cobbles and gravel. Also, there must not be more than 3% silt and clay (<0.53 mm, 270 mesh sieve) in the fill.	0.15 – 0.3mm	4 – 6	2.0
Minnesota	ASTM C33	No spec for No. 100 sieve. No. 200 sieve 0-5% passing. Clean sand must also contain less than three percent deleterious substances and be free of organic impurities.	None Specified	None Specified	1.6
Washington	ASTM C33	No. 100 sieve prefer <4% passing. No. 200 sieve 0-3% passing.	None Specified	None Specified	2.0
Wisconsin	ASTM C33	None Specified	None Specified	None Specified	2.0
British Columbia	ASTM C33	No. 100 sieve 0-4% passing. No. 200 sieve 0-1% passing.	None Specified	None Specified	1.6 – 3.15
Manitoba	CSA A23.1 (ASTM C33)	No. 200 sieve 0-5% passing.	None Specified	None Specified	1.6 – 3.75

Distribution of Area Over Sand Fill

- The dispersal aggregate shall be clean stone (3/4 to 1 inch). The stone shall be washed with not more than 5% passing the No. 200 (75 µm) sieve as determined by ASTM C117, "Test Method for Material Finer than 75-µm (No. 200) Sieve in Mineral Aggregates by Washing" and shall be durable with a hardness of 3 or greater on the Moh's Scale of Hardness. Alternatively, gravelless technologies may be utilized instead of stone.
- The dispersal material shall be leveled to a depth of 6 inches.
- The Puraflo modules shall be placed on the dispersal material so that they are evenly spaced from the sides of the distribution bed and end of the distribution bed with even spaces between each module and the ends of the dispersal area. The minimum spacing from the end of the dispersal material to module end is 1 foot. For spacing calculation, see "Mounded Pad Design Example".

- The Puraflo modules shall be level from end-to-end.

- Connect the force main to the module inlet coupling (incorporating a flexible pipe). Note sizing requirements in Section 5.3 of this guide. The manifold connection shall be configured like the illustration in Appendix 2 and 4 of this guide and shall pass the last module by a minimum of six inches and be capped. It is recommended that a clean-out be brought to finished grade.

Distribution Network (if applicable)

Modules are typically Type A with weep holes; however, Type B modules with distribution network may be used as required by regulatory authority.

- The distribution network must be 2 inch PVC pipe with 3/8 inch orifices spaced between one to three feet. The orifices should be oriented in the 9 o'clock position.
- Each module must have an isolated lateral with clean-out brought to finished grade on each distal end.
- Each individual distribution lateral must be level within 1/4 inch +/- from module drain hole to lateral end.
- Testing was conducted by Anua to demonstrate the ability of the network to reasonably provided uniform distribution. Test results conducted on the network are shown in the diagram below (Each circle represents a collection bucket below a 3/8-inch orifice.)

Dose Volume = 60 Liters

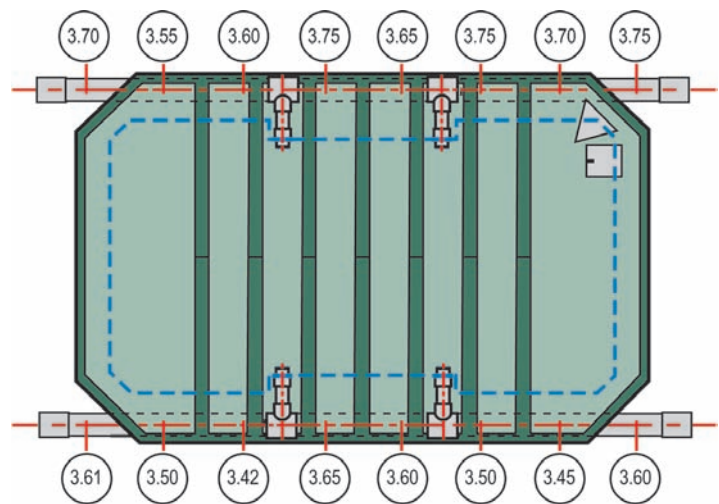

Monitoring Components

- At least three inspection ports shall be spaced at intervals adequate for observation of the absorption area and any ponding at the sand fill surface. The ports shall be anchored and be accessible with at least a four inch opening and a removable watertight cap.
- Each module must have an isolated lateral with clean-out brought to finished grade on each distal end for flushing-out any materials, such as peat particles migrating to the lateral during initial operation of the system.

Installation

- **Pre-Installation:** The full soil absorption area shall be free of any site disturbances. If any disturbance or damage has occurred, installation shall not proceed and the registered installer shall contact the owner and the board of health. Prior to installation the registered installer shall check all elevations in the design plan relative to the established benchmark including the surface contour and the flow line elevation of other components to assure proper flow through the system and freeze protection as applicable. Soil moisture conditions shall be evaluated and basal area preparation shall not proceed when there is risk of smearing or compaction.
- **Site Preparation & Installation:** The mound shall be installed according to the design manual and any referenced resource and shall comply with the following:
 - (1) All vegetation shall be cut close to the ground and removed from the site. Stumps, roots, sod, topsoil, and boulders shall not be removed.
 - (2) The force main should be installed from the upslope side. All vehicle traffic on the basal area and downslope area of the mounded pad should be avoided with installation work being conducted from the upslope side or end of the mounded pad basal area.

Mound Cover

- Once the Puraflo modules are installed and all connections have been made, the distribution media shall be covered with a geotextile fabric used to prevent introduction of soil fines and allow for free movement of air and water.
- The soil cover shall be applied to allow for an approximate depth of six inches after settling, and the mounded pad shall be crowned to promote runoff.
- Soil cover shall be of a quality to allow for oxygen transfer and growth of vegetation.

- (3) The basal area of the mounded pad shall be prepared to provide a sand/soil interface and to improve infiltration if needed. The basal area preparation shall not reduce the infiltrative capacity of the soil surface. The degree of basal area preparation shall be determined on a site by site basis depending on soil conditions. Any basal scarification or other basal area preparation shall be conducted working along the contour. Sand may be incorporated into the basal area during the preparation process. Following basal preparation, a layer of sand fill shall be placed on the entire basal area to prevent damage from precipitation and foot traffic.
- (4) The specified depth and sufficient amount of sand fill shall be placed to cover the basal area, form the absorption area, and shall not be steeper than 3 to 1 side slopes. The distribution area shall be formed to the specified dimensions and the sand surface of the distribution area shall be level.
- (5) Construct and install all components, including the distribution laterals and observation ports.
- (6) Once the Puraflo modules are installed and all connections have been made, the distribution media shall be covered with a geotextile fabric.
- (7) Field test the sand to verify quality with one of the methods outlined below.

Minnesota Method

(from 1995 University of Minnesota "Onsite Sewage Treatment Manual")

Jar Test for Clean Sand for Mounds

Use a 1 quart Mason jar

If the fines that settle out in 1 hour is greater than **1/8 inch**, then the percentage of fines is too great and the sand **SHOULD NOT** be used for mound construction.

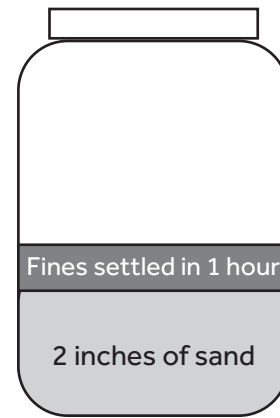

Manitoba Method

(from OWMS Jar Test revised April, 2010)

OWMS – Field Reference Guide Jar Test

Under some circumstances, it may be beneficial to perform a jar test for fines (silt or clay) on the sand when it is received or before it is purchased to determine if the sand supplied meets the specification of the sand ordered.

An 8 hour jar test must be conducted for best results.

The jar test is a “quick” method to determine if the sand contains too many fines. The jar test is not to be used as a replacement for sieve analysis; however the test can be used as a field method to determine that the sand meets CSA A23.1-04 (ASTM C33) specifications.

After settling for several hours, if the layer of fines that settle on top of the sand is thicker than 3.2mm (1/8 inch), the sand contains too many fines and is not suitable for use in a treatment mound. When in doubt the aggregate

supplier should provide an aggregate analysis report to confirm that the product meets the sieve specification.

When a “check” in the sand is required, it is recommended that a sample of the sand be obtained prior to construction and the 8 hour jar test be conducted.

Jar test procedure is as follows:

- Place approximately 2 inches of sand in a glass quart jar.
- Fill the jar with water.
- Shake the jar vigorously to mix the sand and water.
- Set the jar on a level platform and allow to settle for 4–8 hours.
- Upon settling, after 4–8 hours, the layer of fines that settle on top of the sand layer should not be thicker than 3.2mm (1/8 inch).

Tips:

- Take a sample from the middle of the pile.
- It may be necessary to jar test a composite sample.
- It may be necessary to conduct two jar tests.
- When in doubt, obtain the sieve analysis report from the aggregate supplier or send a sample to the laboratory. Be sure to ask the laboratory to include the No. 200 sieve size.

Completion

- (1) The area around the mound system shall be protected from erosion through upslope surface water diversion and provision of suitable vegetative cover, mulching, or other specified means of protection.
- (2) Installer documentation shall include the drawdown test, as specified in Appendix 7, as baseline measure for future O&M and monitoring. Documentation shall be provided to the local health district to be included in the permit record.
- (3) The system shall be backfilled with sandy to loamy soil material and topsoil to the bottom lip of the Puraflo modules.

Mounded Pad Operation and Maintenance

- The mounded pad system shall be operated, maintained, and monitored as outlined in the "Operation and Maintenance Manual" and per requirements of the regulatory authority.
- The O&M of a mound soil absorption system shall include but is not limited to:
 - (1) Checking the mounded pad vegetative cover for erosion or settling and any evidence of seepage on the sides or toes of the mounded pad.
 - (2) Flushing of distribution laterals.
 - (3) Checking for ponding in the distribution area.
 - (4) Monitoring the dose volume to the Puraflo modules and performing the drawdown test as outlined in Appendix 7.
 - (5) Checking for any surface water infiltration or clear water flows from the dwelling or structures into the system components or around the mounded pad soil absorption area.

Mounded Pad System Diagram (typical)

NOTE:

A mounded pad soil absorption component shall not be sited on a slope greater than 25 percent unless the design plan includes special installation criteria.

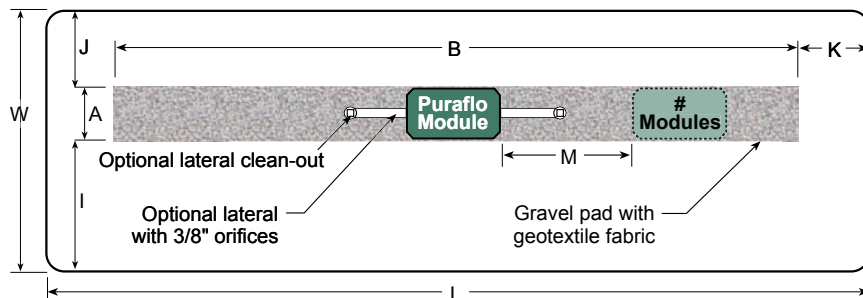
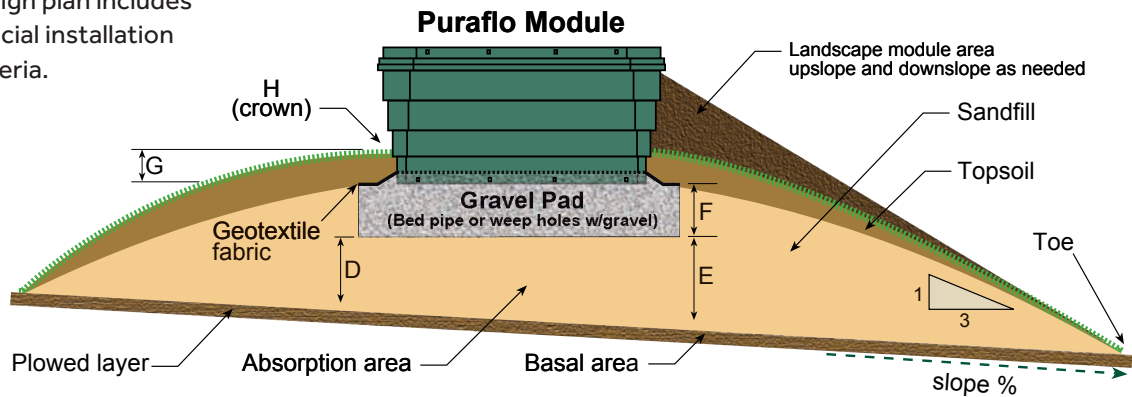

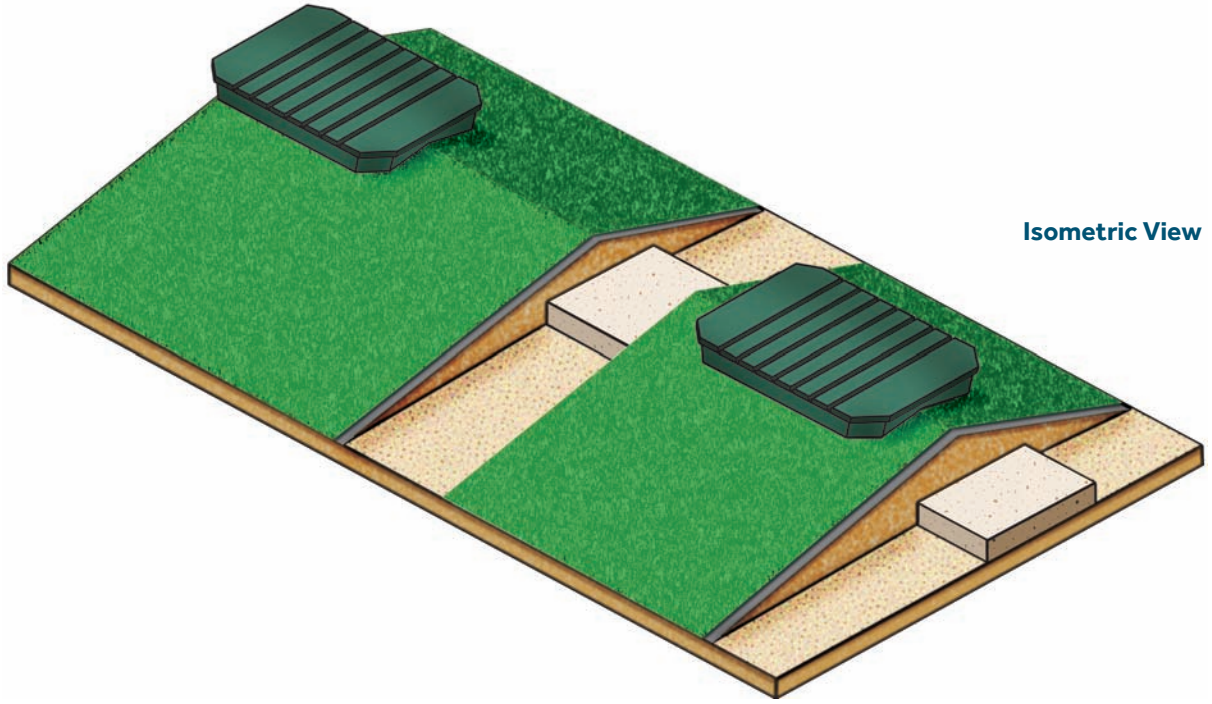

Isometric View

References for Mounded Pad

- British Columbia Ministry of Health. (2007). *Sewerage System Standard Practice Manual*, Version 2. Victoria, BC.
- Converse J.C. and E.J. Tyler. (2000). *Wisconsin mound soil absorption system: siting, design and construction manual*. Small Scale Waste Management Project #15.24. 345 King Hall, University of Wisconsin-Madison, 1525 Linden Drive, Madison, WI 53706.
- Iowa Department of Natural Resources. (2007). *Sand Mound Technology Assessment and Design Guidance*. Des Moines, IA.
- Ohio Department of Health. (2010). Special Device Approval per OAC 3701-29-20(C) *Low Pressure Distribution Sand Filter*. Columbus, OH.
- Ohio Department of Health. (2007). Special Device Approval per OAC 3701-29-20(C) *Sand Mounds with Pressure Distribution*. Columbus, OH.
- State of Wisconsin, Department of Commerce, (2001). *Mound Component Manual for Private Onsite Wastewater Treatment System. Version 2.0*, Division of Safety and Buildings, Safety and Buildings Publication SBD-10691-P (N.01/01).
- Tyler E.J. (2001). *Hydraulic Wastewater Loading Rates to Soil*. Publication #4.43 by Small Scale Waste Management Project (SSWMP): University of Wisconsin, Madison, WI.
- Washington Department of Health. (2009). *Recommended Standards and Guidance for Performance, Application, Design, and Operation & Maintenance Mound Systems*. Olympia, WA.

Type B System: Puraflo Modules Combined with SEPARATE Dispersal

- Refer to section 5 and 9 of this manual.
- All components used in conjunction with the Puraflo Peat Fiber Biofilter must comply with all applicable State or Local rules and codes.
- The septic tank shall be sized according to State or Local codes.
- An effluent filter/screen shall be placed on the outlet of the septic tank that meets the requirements of Section 5.3 of this manual.
- The pump tank shall be sized according to State or Local codes.
- Calculations can be done with the Microsoft Excel Design Sheet.
- The bottom of the stone dispersal area shall maintain a minimum vertical separation distance from limiting conditions per State or Local requirements or 1 foot (6 inches to seasonal high water table). In situ soil must be a minimum of 6 inches.

References

- Allen, D.H. (1980). *Hydraulic Mounding of Groundwater Under Axisymmetric Recharge*. Water Resource Research Center, University of New Hampshire. Durham, NH.
- Converse J.C. and E.J. Tyler. (2000). Wisconsin mound soil absorption system: siting, design and construction manual. Small Scale Waste Management Project #15.24. 345 King Hall, University of Wisconsin-Madison, 1525 Linden Drive, Madison, WI 53706.
- Headley, T.R. (2006). Suitability of Peat Filters for On-site Wastewater Treatment in the Gisborne Region. *National Institute of Water and Atmospheric Research Ltd Project ELF06201/GDC8*. Hamilton, New Zealand.
- International Library of Technology 440. (1926). *Sewerage and Irrigation*, Scranton, PA.
- Kaplan, O. Benjamin. (1991). *Septic Systems Handbook. 2nd Ed.* Chelsea, MI: Lewis Publishers Inc.
- Kennedy, P. and Van Geel, P.J. (2000). Hydraulics of Peat Filters Treating Septic Tank Effluent. *Transport in Porous Media* 41: 47–60. Netherlands.
- Loudon, T.L., Bounds, T.R., Buchanan, J.R. and Converse, J.C. (2005). Media Filters Text. in (M.A. Gross and N.E. Deal, eds.) *University Curriculum Development for Decentralized Wastewater Management*. National Decentralized Water Resources Capacity Development Project. University of Arkansas, Fayetteville, AR.
- National Environmental Services Center. (2004). *Pipeline, Vol. 15, No. 1*. Morgantown, WV.
- National Small Flows Clearinghouse. (1998). *Intermittent Sand Filters Fact Sheet*. Morgantown, WV.
- Patterson, R.A. (2004). Effective Treatment of Domestic Effluent with a Peat Biofilter – A Case Study at Tingha. *Tenth National Symposium on Individual and Small Community Sewage Systems Proceedings*, Kyle R. Mankin (Ed) held in Sacramento, California March 21-24, 2004. American Society of Agricultural Engineers pp 526-536.
- Poeter, E., McCray, J., Thyne, G., and Siegrist, R. (2005). Designing Cluster and High-Density Wastewater Soil Absorption Systems to Control Groundwater Mounding. *Small Flows Quarterly, Winter 2005, Vol. 6, No. 1, pp 36-48*. Morgantown, WV.
- Tyler E.J. (2001). *Hydraulic Wastewater Loading Rates to Soil*. Publication #4.43 by Small Scale Waste Management Project (SSWMP): University of Wisconsin, Madison, WI.
- Walsh, J. and Henry, H. (1998). *Performance of the Puraflo Peat Biofilter Single Pass and Recirculating Systems*. 2nd Southwest Onsite Wastewater Management Conference and Exhibit. Laughlin, NV.

Additional References

- Boelter, D.H. (1968). Important Physical Properties of Peat Materials. *Proceedings of the Third International Peat Congress*. Quebec, Canada.
- Brooks, J.L. (1992). Peat as an Alternative to Conventional Subsurface Soil Adsorption Systems. *7th Northwest On-Site Wastewater Treatment Short Course and Equipment Exhibition Proceedings*. Seattle, WA.
- Couillard, D. (1994). The Use of Peat in Wastewater Treatment. *Water Research* 28(6), 1261-1274.
- Geerts, S.M. and McCarthy, B. (1999). *Wastewater Treatment by Peat Filters. Focus 10,000*. University of Minnesota Extension Service. Duluth, MN.
- McKee, J.A. and Connolly, M. (1995). An Update of the Use of Peat Filters for On-site Wastewater Treatment. *8th Northwest On-Site Wastewater Treatment Short Course and Equipment Exhibition Proceedings*. Seattle, WA.
- Patterson, R.A. (1999). Peat Treatment of Septic Tank Effluent. *Proceedings of On-site '99 Conference- Meeting the Challenge: Making Onsite Wastewater Systems Work*. University of New England, Armidale, Australia.
- Patterson, R.A.; Davey, K. and Farnan, N. (2001). Peat Bed Filters for On-site Treatment of Septic Tank Effluent. *Proceedings of On-site '01 Conference: Advancing Onsite Wastewater Systems*, R.A. Patterson & M.J. Jones (Eds). Published by Lanfax Laboratories, Armidale, Australia.
- Pérez, J.I., Hontoria, E., Zamorano, M. and Gomez, M.A. (2005). Wastewater Treatment Using Fibrist and Saprist Peat: A Comparative Study. *Journal of Environmental Science and Health - Part A: Toxic/Hazardous Substances and Environmental Engineering*, 40: 1021-1032.
- Pérez, J.I., Ramos, A., Ordóñez, J. and Gómez, M.A. (2007). Dual-stage Peat Beds in Small Community Wastewater Treatment. *Journal of Environmental Science and Health, Part A*, 42 (8), 1125-1130.
- Rana, S. and Viraraghavan, T. (1987). Peat Filtration of Septic Tank Effluent. *Proceedings 1986 Annual Conference Canadian Soc. Civil Eng.* Toronto, Canada
- Ronkanen, A.K. and Kløve, B. (2005). Hydraulic Soil Properties of Peatlands Treating Municipal Wastewater and Peat Harvesting Runoff. *Suo, Peat and Mires* 56(2), 43-56. Helsinki, Finland.
- Viraraghavan, T. (1993). Peat-Based Onsite Wastewater Systems. *Journal of Environmental Science and Health - Part A: Environmental Science and Engineering*, 28: 1-10.



P.O. Box 77457
Greensboro, NC 27417

T 336.547.9338
F 336.547.8559
anuainternational.com

